



Owner's Manual and Operating Instructions

MODEL CB6V

6-INCH CABBING MACHINE



Caution: Read and Understand
all Safety and Operating Instructions
before using this equipment



Introduction

The beautifully engineered Highland Park Lapidary CB6V cabbing machine has an improved overall design. Features include a sturdy, stainless steel main body, an increased width of the whole machine to fit 6 wheels with room to spare, an adjustable water delivery system, a precision ground vibration-free main shaft, and large drain ports in the bottom of the machine for easy cleaning. An ergonomically curved stainless steel armrest eliminates unnecessary strain on your wrists. The Model CB6V was built with the lapidarist in mind, designed to give comfort, high performance, and convenience to the user.

Table Of Contents

Product Safety	1
Machine Specifications	3
Setting Up Your Cabbing Machine	4
Assembling the Machine	5
Installing the Light.....	5
Installing the Water Reservoir.....	6
Installing the Drain Hose.....	7
Changing the Wheels.....	8
Installing the End Guards.....	10
Adjusting the Belt.....	10
Startup	11
How to Break In Your Wheels.....	12
Maintenance	12
Greasing the Bearings.....	12
Cleaning Out the Valves.....	13
Using the Machine	14
Making a Cabochon.....	14
Shaping the Dome.....	16
80 Grit Diamond Wheel.....	16
20 Grit Diamond Wheel.....	17
280 Grit Resin Wheel.....	19
Polishing.....	19
600 Grit Resin Wheel.....	19
1200 Grit Resin Wheel.....	20
3000 Grit Resin Wheel.....	20
Final Polish.....	21
Making a Domed Specimen	22
When Should I Change My Wheels?	22
Troubleshooting	24
Warranty Coverage	25
Exploded Views And Parts Lists	26
CB6V Part List.....	26
CB6V Variable Speed Motor Assembly.....	32
CB6V Brushless Dc Motor Assembly Screws And Fasteners.....	33
CB6V Bucket & Fitting Assembly.....	34
CB6V Polish Backer Pads.....	35
CB6V Screws & Fasteners.....	36

Safety Precautions

Used incorrectly, all electrical equipment carries some risk. To eliminate danger to either yourself or the machine, please read and follow all safety, operating and maintenance instructions! Failure to *read, understand and follow* these instructions could result in injury or death to you or others, or result in damage and/or reduced equipment life.

EYE PROTECTION

Safety glasses should always be worn when operating this machine. Regular eyeglasses do not provide proper protection and may not prevent eye injury.

HEARING PROTECTION

To reduce the possibility of hearing loss, always use hearing protection when operating this machine.

PROTECT YOUR LUNGS

An NIOSH certified dual cartridge respirator for dust (P95) should always be worn when running the machine, because rock dust can be hazardous to your health. While water on the wheels does reduce dust, dust particles can be carried in the mist coming off the wheels. This particle-filled mist can also be inhaled into the lungs, which is why we recommend always using a respirator when operating the cabling machine.

WARNING: *Some materials contain minerals or metals that can be more toxic. For instance, metallic ores may contain some toxic materials, so before grinding and polishing any unfamiliar material, make certain that it will not produce toxic fumes or dust. Extra protection may be necessary for more toxic materials.*

AVOID LOOSE CLOTHING AND HAIR

Do not wear loose clothing, gloves, neckties, rings, bracelets or other jewelry that may be caught in moving parts. Wear protective hair covering to contain long hair. Non-slip footwear is also recommended.

DO NOT OPERATE MACHINE WITH GUARDS REMOVED

To prevent injury, never operate the machine without the guards in place.

CONNECTING AND DISCONNECTING POWER

- **DISCONNECTING** The machine should always be disconnected (unplugged) before servicing or when changing wheels.
- **CONNECTING - REDUCE THE RISK OF UNINTENTIONAL STARTS** Make sure the ON/OFF switch is in the OFF position before plugging in the machine.

ELECTRICAL SAFETY

Never touch electrical wires or motor components while the motor is running. Exposed, frayed or worn electrical wiring and plugs can be sources of electrical shock that could cause severe injury or burns.

Never touch electrical wires or motor components while the motor is running. Exposed, frayed or worn electrical wiring and plugs can be sources of electrical shock that could cause severe injury or burns.

- If an extension cord is used, it must not be longer than 12 feet and must be at least 14-gauge wire with a ground.
- Use this tool only with the proper power source 120V 60 Hz.
- If the wiring becomes damaged or frayed, replace it immediately.
- Do not allow water to come in contact with electrical components, and do not connect or disconnect the power with wet hands.
- Disconnect the power before servicing the machine or changing the wheels

ROTATING OR MOVING PARTS

Keep hands, feet, hair, and clothing away from all moving parts to prevent injury. Never operate the motor with covers, shrouds or guards removed.

KEEP WORK AREA CLEAN

- Cluttered work areas invite accidents. **Keep your work area clean and organized.**
- **DO NOT USE IN DANGEROUS OR HAZARDOUS ENVIRONMENTS** Do not operate equipment in dangerous or hazardous environments. Do not use power tools in damp or wet locations nor expose them to rain. Always keep the work area well lighted. Always work in a well-ventilated area.
- **KEEP CHILDREN AWAY** All visitors and children should be kept at a safe distance from the work area.

WORK METHOD

- **DO NOT PRESS TOO HARD AGAINST THE WHEELS:** Your machine will do a better job, and the wheels will last longer, if you use the appropriate degree of pressure against the wheels. Pressing too hard can damage the wheels, especially the higher grit resin wheels.
- **USE THE RIGHT TOOLS TO SERVICE THE CABLING MACHINE:** Do not force a tool or an attachment when servicing or operating this power tool. Use the correct tools for service or adjustments.
- **DO NOT OVERREACH:** Keep proper footing and balance at all times by not overreaching.
- **DO NOT OPERATE A TOOL WHEN TIRED:** When tired, take a break and relax.
- **NEVER LEAVE A TOOL RUNNING UNATTENDED – TURN POWER OFF:** Always turn the tool off when leaving the work area or when work is finished.

MAINTAINING THE MACHINE

- **CHECK FOR DAMAGED OR WORN PARTS** Before using the machine, check for damaged parts or wires. A guard or any other part that is damaged or worn should be replaced. Regularly check moving parts for proper alignment or binding.
- **USE RECOMMENDED ACCESSORIES AND PARTS** Consult the owner's manual for recommended accessories and parts. Using improper parts and accessories may increase the risk of personal and/or bystander injury.

Specifications

Cabbing Machine Model	CB6V
Machine Weight	78 lbs
Main Motor	
Horsepower	1/2 HP
Machine Voltage	110V/60Hz
110 volt / 60 Hz	0-1725 RPM
Motor RPM	1 inch
Arbor Shaft	6" (152 mm) diameter
Wheel Size	

MODEL CB6V 6 WHEEL VARIABLE SPEED 304 STAINLESS STEEL CABBING MACHINE

Motor: The Model CB6V comes with a heavy duty 1/2 horsepower Brushless DC Variable Speed 0- 1725 RPM.

Belt: The CB6V uses a serpentine type belt similar to what is used in automobiles, these belts don't have the associated "thump" of typical v-belts and are very quiet running. Our units have a lot of motor power, so the serpentine belt is preferred to reduce belt slippage on start up particularly when running the heavier sintered diamond wheels.

Frame: The CB6V heavy duty framework is constructed from 14 gauge 304 stainless steel so it will never rust. 304SS is a more pure stainless steel than is offered by other manufacturers and is completely non magnetic.

Wheel Spacing: The Highland Park CB6V Cabbing machine is designed with a precision ground shaft that allows 1 1/2" between wheels when using 1.5" wide wheels. The machine comes complete with wheels and spacers and is ready to run. Additional sizes of spacers are available to accommodate any type of wheel configuration.

Drains: There are two large drains, one on each side of the machine allowing easy evacuation of the waste water. Additionally, the drains are positioned below the bottom of the tray, so the water can drain completely, unlike most common drain designs.

Water Delivery: The Highland Park CB6V Cabbing Machine has a drip feed water delivery system. The water feed fitting on the back of the unit accepts 6mm poly tubing and feeds both sets of valve assemblies that are located under the top of the unit. The valve outlets are positioned over each wheel and the felt wipers assist in the dispersion of the water across the face of each wheel. The valves have removable needles that can easily be removed for cleaning or for servicing the seals.

Main Shaft and Bearings: The CB6V Main Shaft is made from precision ground 316 Stainless Steel and is mounted on 2 heavy duty 1" bearings for smooth vibration free operation and long bearing life.

Wheels: The CB6V comes with the following wheels: 80, 220 grit plated grinding wheels and 280, 600, 1200, 3000 grit resin polishing wheels.

Accessories: Unit also includes a gooseneck LED Lamp and both leather and felt buffing disks.

Setting Up Your Cabling Machine

Find a suitable work space where you can sit or stand in front of the machine, making sure it is on a solid, flat surface. Place the machine at a height that allows your arms to rest on the ergonomic wrist supports, as this diminishes strain on the lower back.

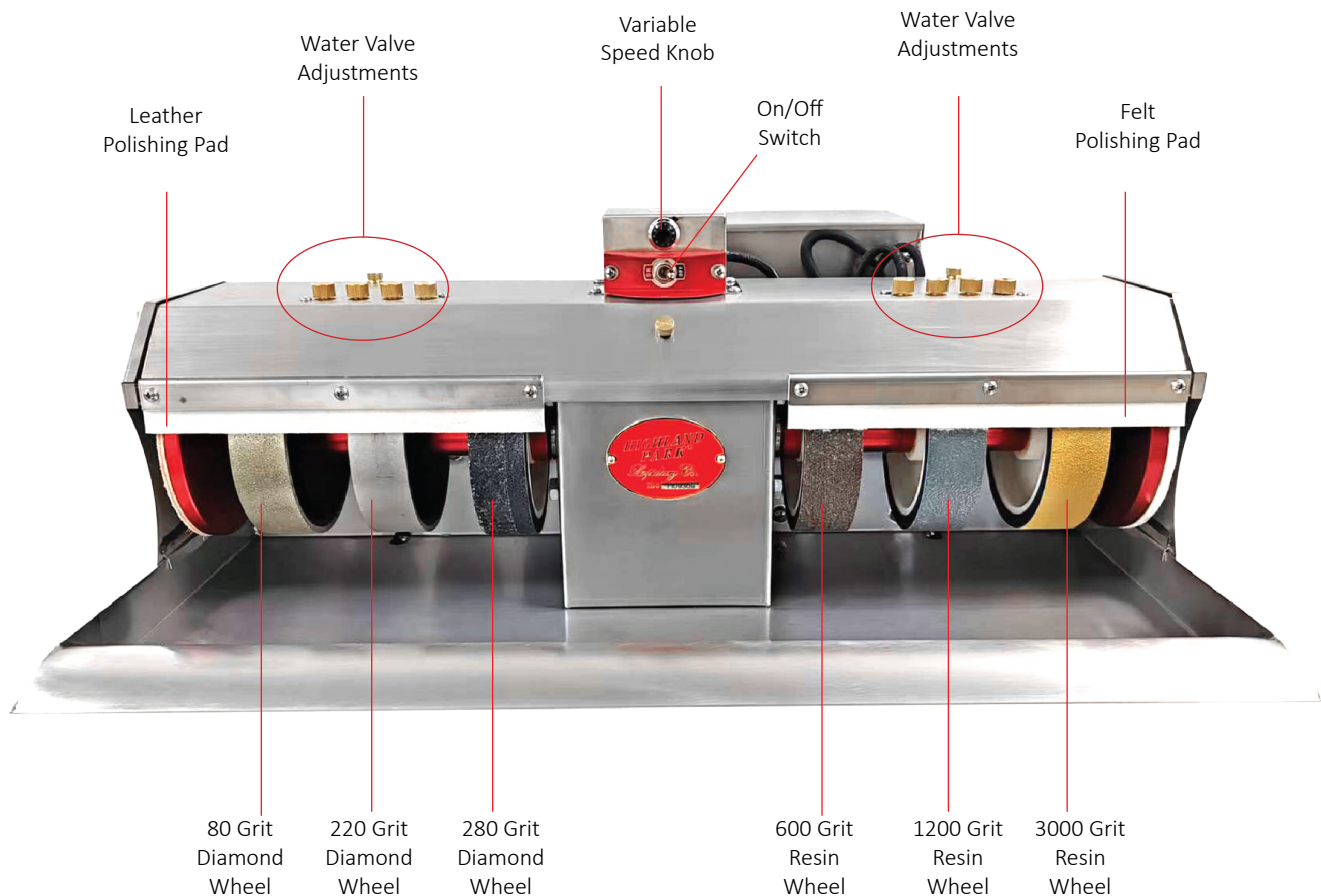

The above photo shows the various parts and controls for your CB6V. The machine should be plugged into a circuit rated at 8 amps.

Assembling The Machine

INSTALLING THE LIGHT:



Light Assembly



Light Mount



1. Align Assembly with Screw Holes



2. Insert & Tighten Screws



3. Tighten screws, plug in the light

To install the light:

- Remove the light assembly from the box and align the bottom of the assembly with the light mount on top of the machine.
- Place one of the included screws into each of the four holes.
- Using a Phillips head screwdriver, tighten screws until light is secure and does not wobble. Do not overtighten, as this can strip the screw threads.

INSTALLING THE WATER RESERVOIR



1



2



3

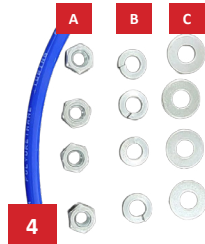

4



5

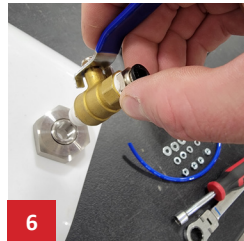

6



7



8

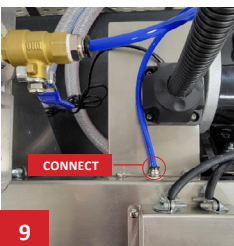

9

- The water reservoir includes a bucket with installed drain plug, a hose with two QD connections, a bracket, nuts and washers.
- You will need the following tools to attach the water hose both the bucket and the machine:
 - Two larger adjustable wrenches
 - 7/16" nut driver
- Place the bracket on the back of the left side of the machine, as you are facing it. The bracket holes will align with the studs on the rear of the machine.
- Put the flat washer (C) on each stud first, then the lock washer (B), then the nut (A).
- Using a 7/16" nut driver, tighten the hex nuts so that the bracket attaches tightly to the machine. Do not overtighten.
- The water reservoir as installed works with a drip feed. Use plumber's tape around the threads of the valve that is attached to the bucket.
- Next, screw the valve securely into the connector. Then, tighten it with a large adjustable wrench on the inside fitting and a smaller adjustable wrench on the valve to tighten the valve into the fitting. Do not overtighten.
- Insert the water hose into the valve about 3/8". The QD connector will grip it tightly, with no need for any tools. Pull on the tubing after it's inserted to make sure that it was inserted enough, if it comes out when you pull on it, then you need to press a bit harder when inserting the tubing.

9. Insert the other end of the hose into the QD fitting that's on the top cover of the machine. Again, no tools needed. This is what it should look like finished
10. Put water in the reservoir, then open the valve. Check the lines to make sure they are not leaking. If leaks appear, push the lines into the QD fittings more securely.

The machine also can be plumbed directly to a water line or a 5-gallon bucket and pump. When using an exterior water reservoir, be sure that the water is clean. Loose debris can clog the valves and impede the flow of water to the wheels, making it necessary to clean the valves. If plumbed directly to a water line and the water pressure is too high, the valves may drip a little, even when turned off. Most people have optimal results using the reservoir.

INSTALLING THE DRAIN HOSE



1. This is the drain hose, along with tools you will use: an adjustable wrench and 7 mm nut driver.
2. Place the hose clamp loosely on the end of the hose.
3. Using the adjustable wrench, remove the two plugs that are located on the bottom back of the CB6V cabbng machine.
4. Once you have the plug out of the drain outlet, you are ready to put the hose in place.
5. Position the hose as shown to prepare to install it.. The hose clamp will not be at the end of the hose yet.
6. Slide the hose over the drain outlet until it touches the back of the sheet metal, then slide the hose clamp into position over the drain outlet.
7. Tighten the hose clamp, then repeat these steps on the second drain port.
8. The installed drain hose is now ready to get to work!

CHANGING THE WHEELS

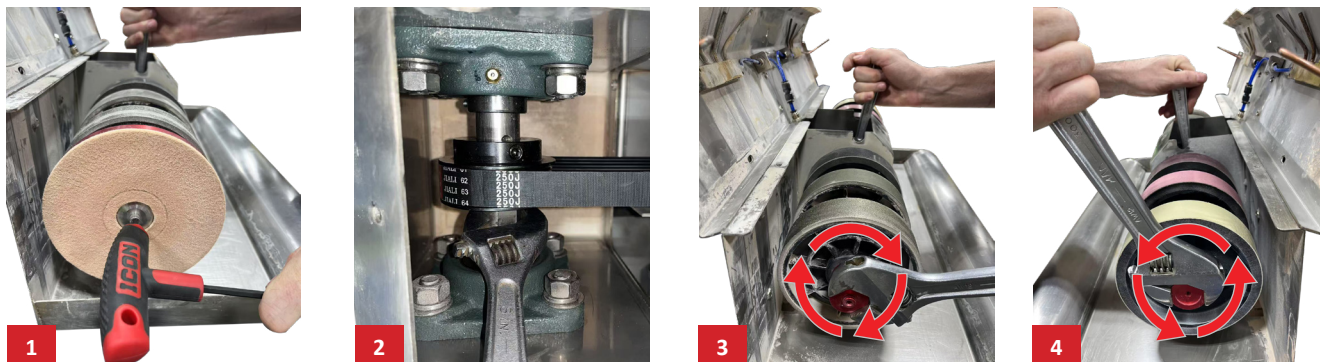

1. In order to change any of the wheels, you first must remove the polishing pad from the end of the shaft. On the right side it has right hand threads, so the pad will unscrew counterclockwise. On the left hand side, it has left hand threads, so the pad will unscrew clockwise.
2. Often this can be done simply by holding the wheel, but if more force is required, remove the cover and put a wrench on the center of the shaft.
3. To remove the wheels, place a wrench on the center flat of the shaft, where the bearings are located, and then a wrench on the end nut and unscrew the nut. Using both hands, slide each wheel and spacer off the ends of the main shaft. If on the lefthand side, it's a lefthand thread. *(Turn the wrench in the direction of the arrows on image #3 to loosen the nut)*
4. The righthand side has a righthand thread. *(Turn the wrench in the direction of the arrows on image #4 to loosen the nut)*
5. When sliding the wheels back onto the axle, place a spacer between each wheel to your preferred layout. The CB6V is designed so that there can be 1.5" of space between the wheels when you are using 1.5" wheels.

SPACERS

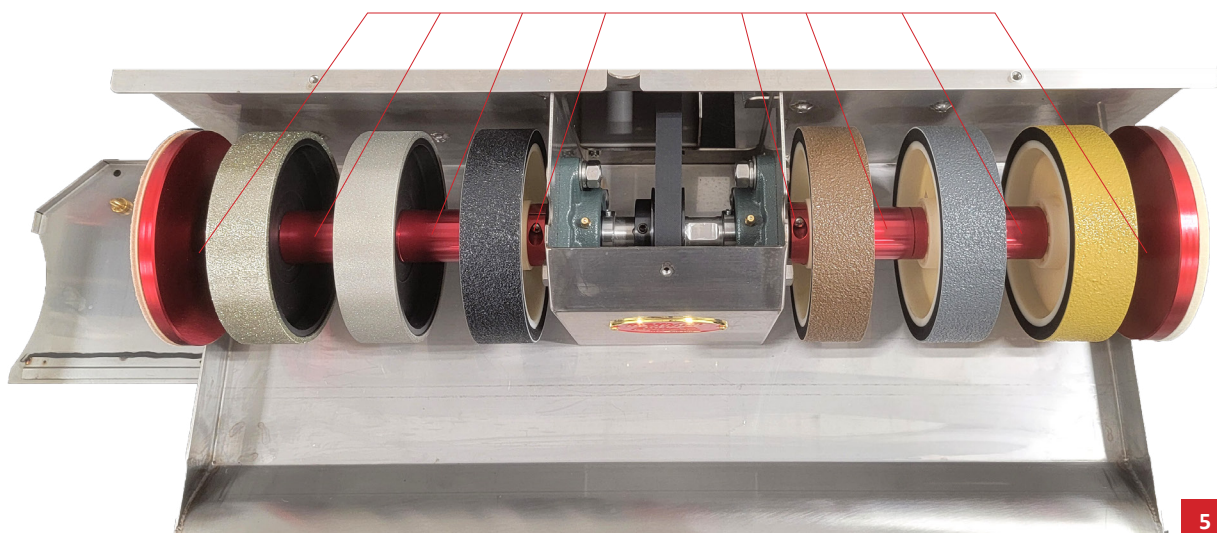



6. When placing the last wheel on the end of the shaft, be sure that the threads extend $1/4''$ past the hub of the wheel, or the nut may bottom out and the wheels may slip. If it extends more than that, add or remove spacers to get the exposed threads as close to $1/4''$ as possible.

Note: *If the shaft is sticking out too far, the nut will bottom out on the threads before tightening on the wheels. If this happens, the wheels will slip during use.*

COPPER LINES should be aligned in wheel centers.

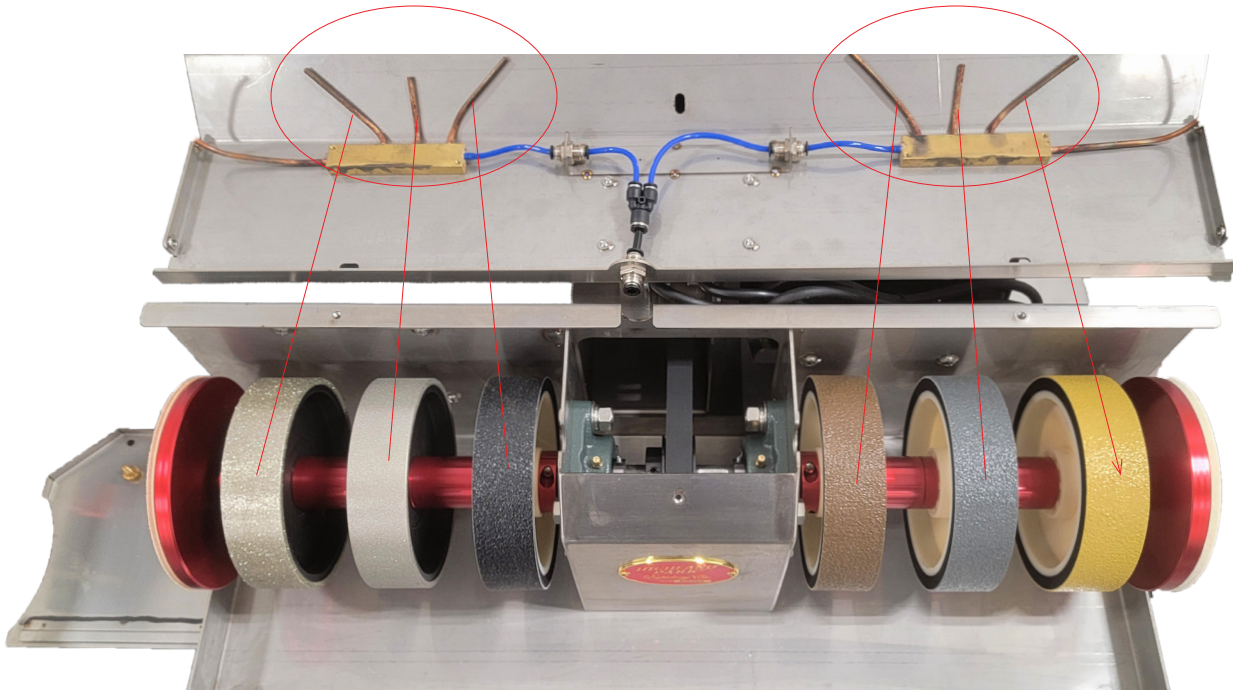

7. If moving the wheels to a different configuration, adjust the copper water line to place the water in the center of the wheel.

INSTALLING THE END GUARDS

End guards for the CB-6 are simple to install, using just two brass thumb screws to secure them in place:

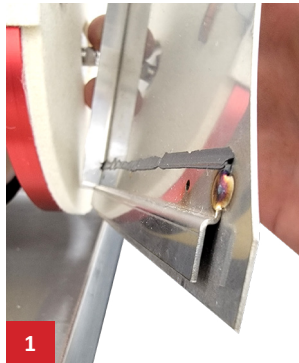

1. Align the bottom slot of the side guard with the tray and then slide it down onto the tray.
2. Place the left end guard with the edges wrapping around the top of the machine. Use your fingers to tighten the brass screws that hold it in place.
3. Place the right end guard with the edges wrapping around the top of the machine. Use your fingers to tighten the brass screws that hold it in place.

ADJUSTING THE BELT

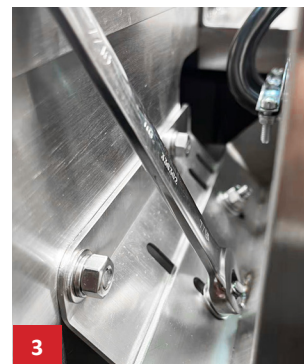

UNPLUG YOUR MACHINE before adjusting the belt.

1. With the top cover removed, check the tension of the belt. If it has more than 1/2" movement with light pressure, then the belt should be adjusted.
2. Identify the four mounting bolts that hold the motor in place. There are two on the top, and two on the bottom.

The preferred tool is a 7/16" wrench .



3. Loosen the nuts on the mounting bolts, but do not remove them.
4. Place a lever against the motor and increase the tension on the belt by pressing the motor away from the frame.
5. Begin to tighten the nuts on the mounting bolts, but be careful to keep the motor straight so the belt runs true.
6. Tighten all four mounting bolts. Do not overtighten and strip the threads. Be sure to tighten bolts on both sides of the motor.

Startup

Flip the On/Off switch to start the machine, with the brushless DC motor control, there will be a few second delay before the motor starts turning . If the machine does not start turning after a few moments, then make sure that the speed control knob is not turned all the way down. When you first start up your machine, you will hear a rubbing sound from the front of the wheels. This is normal, and is just the sound of felt rubbing on the wheels. As felt absorbs moisture and relaxes, the sound will diminish.

With your variable speed machine, Highland Park offers an optional tachometer for finding the perfect speed for your material. Once you find a speed you like for cutting and polishing, a tachometer will allow you to replicate it exactly. Speed can also be adjusted by listening to the

sound of the machine.

Hard materials like agate and jasper can take higher wheel speeds than softer materials like turquoise or opal, as agate and jasper are harder and can take more heat from friction. Every stone and every cutter is different - adjust your machine to something that works for you.

Diamond wheels require a break-in period before working with soft material, so we recommend cutting agate, jasper or similar rocks with a Moh's hardness of 7+ for your first few cabs. After 5-10 minutes, the wheels will be fine for all materials. Breaking in a wheel will remove little sharp points that may be on the wheel's surface.



PRO TIP: How to Break In Your Wheels

On your 80 grit wheel, use a piece of agate or other stone that is Mohs 7 or harder. Round it off and get it relatively smooth. After it is rounded, work the piece through the resin wheels until any sharp points or rough textures on the surface of the wheel are smoothed down. They are now ready for any material. NEVER push a sharp edge of the stone into the soft wheels, as this can cause damage.

Maintenance

GREASING THE BEARINGS

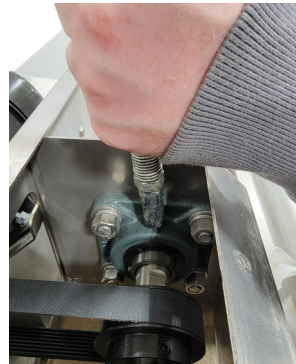
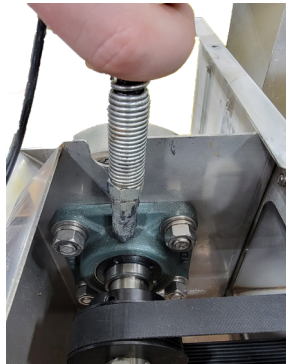

1. To grease the bearings, remove the top cover, exposing the two bearings.
2. Using a standard grease gun and NLGI-2 standard lithium grease, put one to two pumps in each bearing, watching for when the grease starts to come out around the seal. When grease starts to appear at the seal, the bearing is full.

CLEANING OUT THE VALVES



1. Remove the valve that is connected to the wheel where water is either leaking or not flowing properly. Debris in the valve seat can cause either of these conditions.
2. Gently blow air or flow water through the valve in order to remove blocked debris. Do not put a metal tool down into the valve, as you can scratch the valve seat and damage the valve.
3. When you are finished flushing the valve, you can replace the valve needles.

Using The Machine

Now that you are set up for success, let's get started making your cabochon! The cabochon-making process moves left to right on the machine, starting on the 80-grit wheel, followed by the 220, then the 280 resin wheel. The polishing process begins on the 600 wheel (first wheel on the right hand side), followed by 1200 and 3000 wheels.

WATCH THE VIDEO: [How to Make a Cabochon](#)

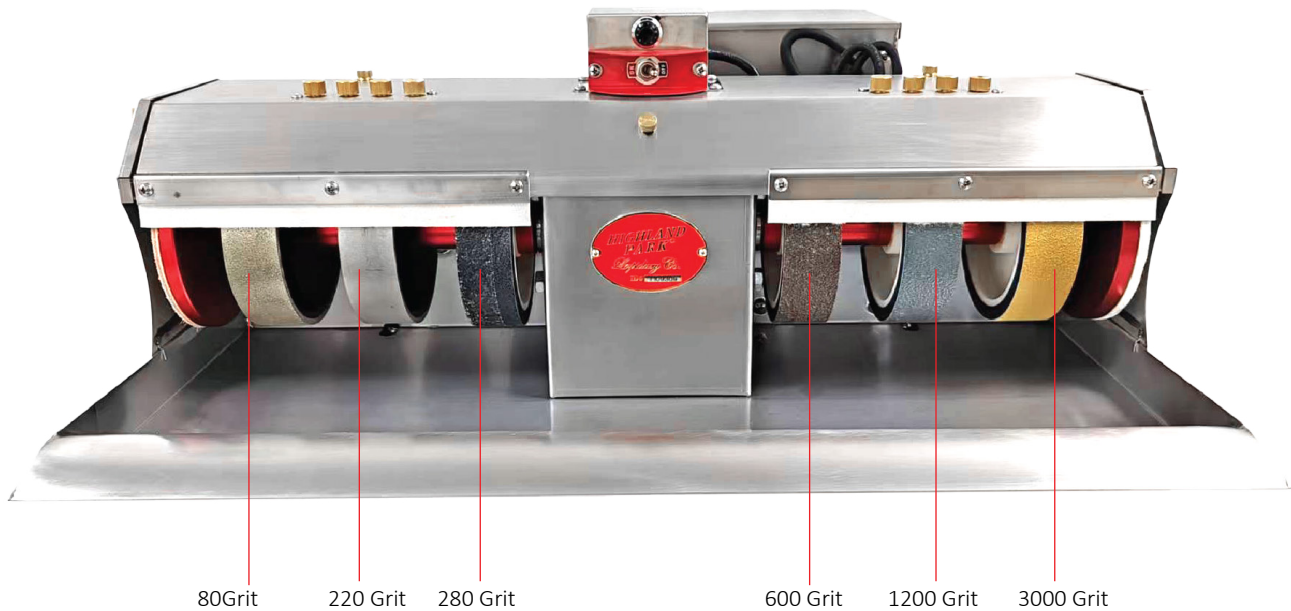

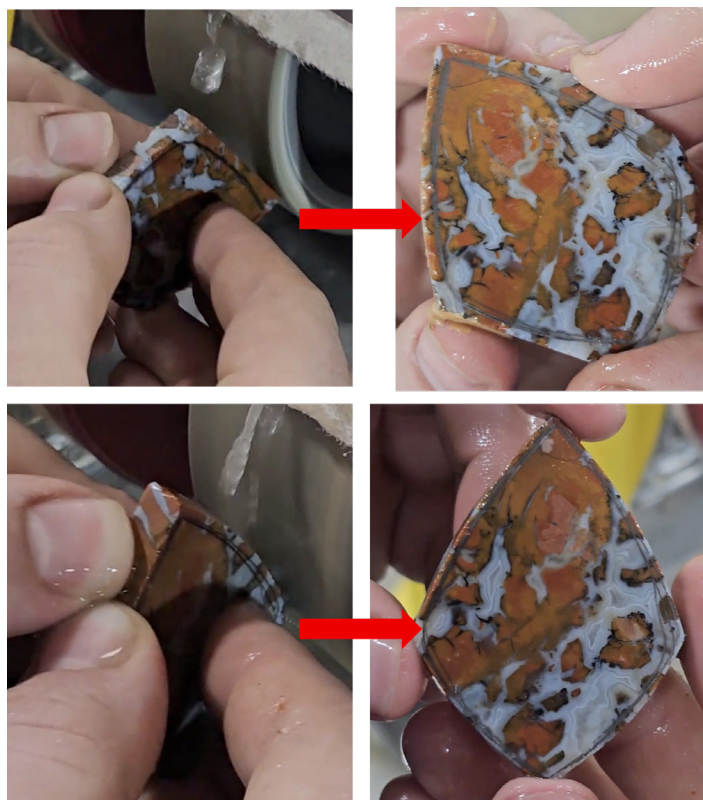

SHAPING THE PRE-FORM

1. Start working on your 80 grit plated wheel. The first step is to get the appropriate water flow on the wheel; make sure the flow is enough to keep debris from accumulating on the wheel, but not so much that water is splashing everywhere. The water will keep the stone lubricated, reducing friction that creates unwanted heat.
2. Using both hands, hold the pre-form at 90 degrees to the grinding wheel and allow the wheel to smooth the edges. If you have used a template for the shape, grind down to the line you made. If making a cabochon for stone setting, grind a slight angle (6-11 degrees) along the edge, with the bottom tapering to the top.

SHAPING THE DOME

Once you have ground your preform into the perfect shape, the next step is to start the dome. Cabochons must have a dome, whether high or low, in order to eliminate flat spots and allow the entire face to take a great polish. This step requires practice and patience.

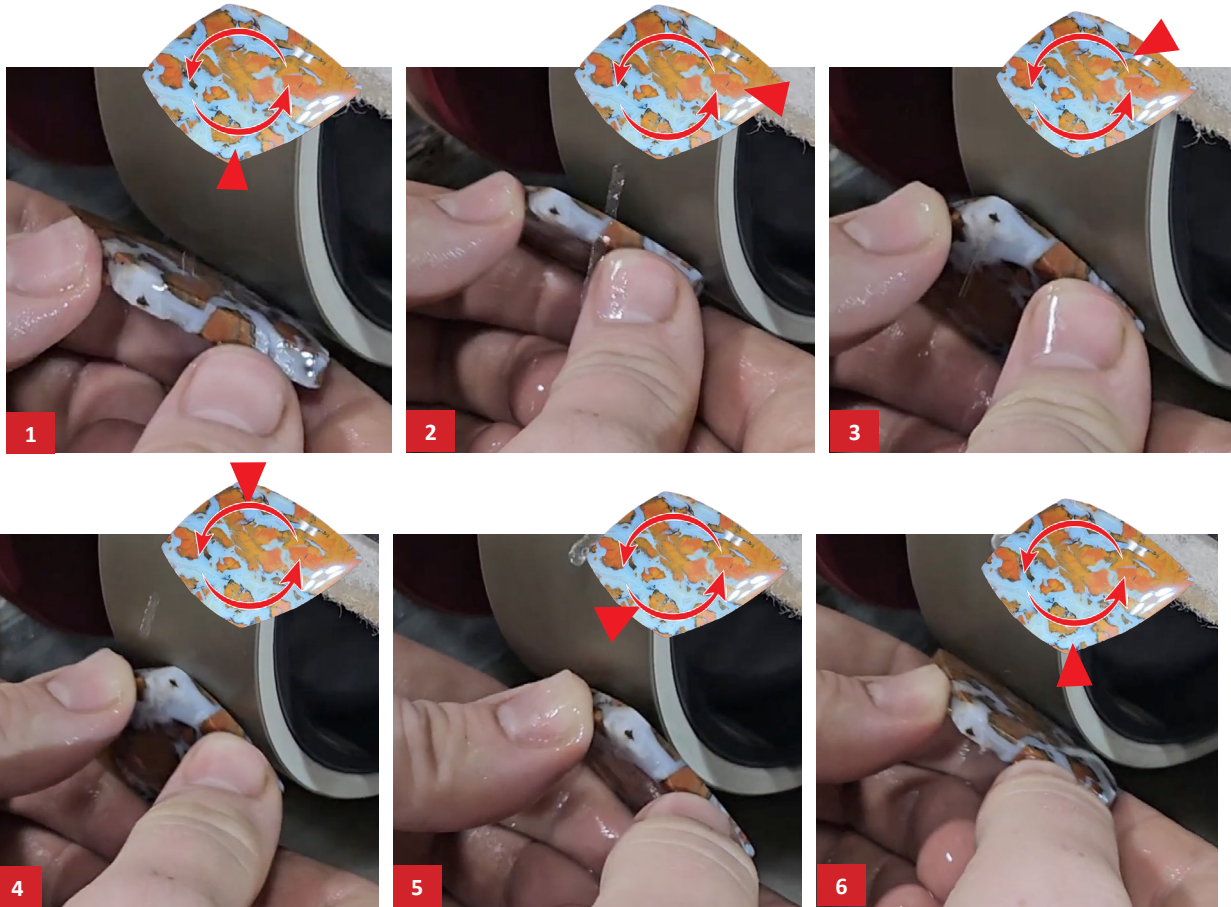

- To make a dome, hold your preform in both hands with the face parallel (flat) to the 80-grit wheel. (The arrow in the above photo indicates where the stone is touching the wheel). Tilt the bottom edge to make contact with the wheel, and begin grinding around the edges at a slight angle (about 15-25 degrees, depending on how thick your stone is), tracing an angled circle around the preform's outer edge. The grinding motion to get a dome using a circular rocking motion that can either be done counterclockwise or clockwise. The arrow on the diamond represents where the cab contacts the wheel.
- Some users prefer to use a dop stick to hold their cabochons, to keep their fingers away from the wheel or provide better leverage. At left is the HP Dop Pro ([SKU: DOP001](#))
- Once you have made an angle cut all the way around the stone, continue the



circular motion working inward, making smaller and smaller rotations until you get to the center of the stone. It helps to envision this as a spiral, moving from the outside to the very center, always keeping the preform at a slight angle. Another helpful image is to picture a coin spinning, making smaller and smaller movements until it reaches the center. Spin a coin. Watch the motion of the coin as it starts to get flat on the table. Imagine doing that same motion with the cabochon on the wheel - only slower.

- Next, turn the stone 180 degrees and do the same thing, working from the outside to the center. Again, imagine that you are tracing a spiral on the stone with the wheel. The hand motion to accomplish this takes practice, but once you master it, your cabochons will be perfect every time.

220 Grit Wheel

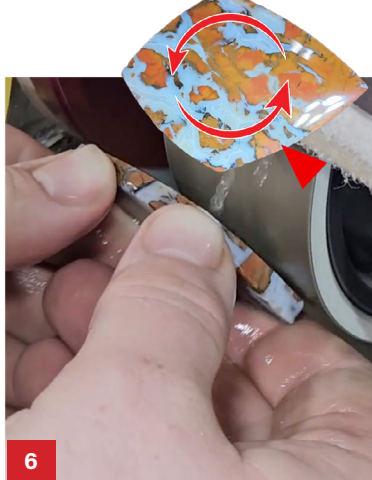
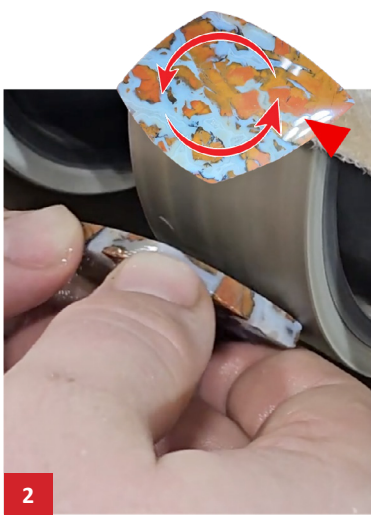

After the 80 grit wheel, the next step is the 220 diamond wheel. You will use the exact same process on this wheel (and the remaining wheels) as you did on the first wheel - first, rotate the outer edges against the wheel to smooth

and start polishing. Next, work from the outside face to the center, making larger to smaller circles with the face of the stone.



NOTE: With EACH WHEEL, repeat the process of grinding and smoothing the sides and the rear edge of the cabochon.



If you feel like your dome has started properly, dry the stone completely and look at it under a bright light. Any flat spots or deep scratches will be very apparent on a dry stone. If there are flat spots, go back to the 80 grit wheel. Repeat until the dome is well-started, and no flat spots appear. With all wheel stages, work across the entire surface of the wheel to ensure even wear. There will be smaller scratches that appear; these will be worked out on the next wheel.

Check the back edges to see if they are still smooth. If some minor chipping appears, use the 220 grit wheel to smooth them out. For stone setting, jewelers suggest a small 45-degree chamfer all around the base of the stone (right), which leaves room for solder and makes it less prone to breakage.

When finished with the 220 grit wheel, your stone surface should be fairly smoothed out. You also will have gotten rid of all the 80-grit scratches, although some finer scratches made by the 220 grit wheel will be present.

280 Grit Wheel



After the 220 grit wheel, move over to the 280 grit resin wheel. Use the same process you have used on the first two wheels: first grind the outside edge, then work in a circular motion from the outer edge to the center. As you work with the resin wheel, you will begin to get a feel for the pressure required. The wheels flex slightly when working, making it easier to grind more surface at once. Allow the wheel to do the work, rather than putting too much pressure against the resin.

Because you are no longer shaping the stone, just smoothing it out, use bigger circular motions across the wheel.

NOTE: Resin wheel surfaces are softer and more pliable than diamond plated wheels. Do not cut into the resin wheel with a sharp edge, as it will damage the surface of the wheel. The pressure with which you will push the stone against the wheel is also less. Pushing too hard can damage the wheel.

POLISHING

600 Grit Resin Wheel



Once you have the dome perfectly formed and the flat spots and scratches smoothed out, It's finally time to work your stone into a mirror polish. Move on to the 600 grit polishing wheel and repeat the motions with the stone - first the outside edges (girdle), then move in big, sweeping motions from the outer edge of the dome to the center. Repeat this process, rotating the stone's orientation to ensure an even girdle and smooth polish.

1200 Grit Resin Wheel

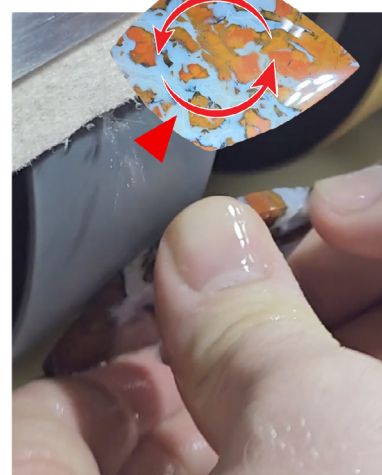
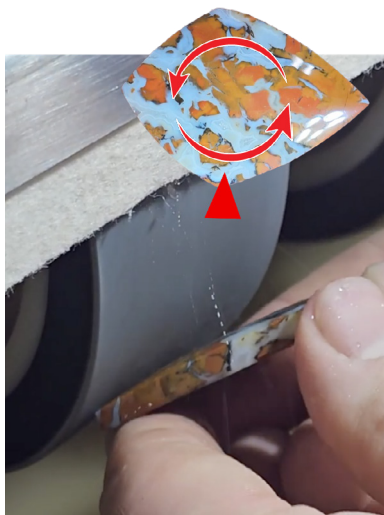

Move on to the 1200 grit resin wheel and repeat the motions with the stone - first the outside edges (girdle), then move in big, sweeping motions from the outer edge of the dome to the center. Repeat this process, rotating the stone's orientation to ensure an even girdle and smooth polish.

3000 Grit Resin Wheel



The 3000 grit resin wheel is your last step before the final polish. As before, repeat the motions with the stone - first the outside edges (girdle), then move in big, sweeping motions from the outer edge of the dome to the center. Repeat this process, rotating the stone's orientation to ensure an even girdle and smooth polish.

FINAL POLISH



Your CB6V comes with one felt wheel and one leather wheel. The leather wheel used with cerium oxide is ideal for polishing agates and jaspers and most hard stones. The felt wheel can be better for soft materials using 50k diamond compound. Buffing your cabochon to a mirror polish takes a very fine grit, either diamond powder, cerium oxide or another polishing agent.

To renew the charge, take a teaspoon of cerium oxide ([SKU: PP0102](#)) and start mixing water in until it becomes a smooth, thin paste. Use a toothbrush, old paintbrush or your finger to apply the paste over the face of the wheel.

To charge the leather wheel for the first time, make a paste that is 1/2 cerium oxide (Part #) and 1/2 water. Work the paste into the wheel and let it dry flat overnight. Charging the felt wheel with diamond is a similar process, depending on whether you use spray or paste.

To polish your cabochon, use a spray bottle to mist the surface of the charged felt. You will be polishing the bottom 1/3 to 1/2 of the cabochon as you work it, turning to make sure you reach all of the face. Avoid digging the top edge into the wheel, as this will likely cause the cab to spin out of your hand! As it is being polished, the stone should have enough drag that it feels like the wheel is trying to pull it out of your hand - but not so much that it actually does.

MAKING A DOMED SPECIMEN:

Making a domed specimen is similar in process to making a cabochon - your movements just will be bigger. Grind away the edges (working from the outside edge to the center) until there is a visible dome from edge to edge. Remember that the dome doesn't have to be huge - just enough to allow the wheel to touch all the faces of the surface. Since the wheels are round, polishing a flat surface is very difficult, so doming is necessary.

Once the rock is domed, follow the same order of wheels and procedures as for cabochons. After polishing, you will have an attractive specimen for your collection - or someone else's!



WHEN SHOULD I CHANGE MY WHEELS?

Used correctly, the wheels included on your CB6 or CB6V, or the ones purchased with your CB6V, should last for many, many cabs. However, after heavy use, wheels will begin to show wear.

The 80 grit diamond wheel gets the heaviest grinding use, and so is most likely to need replacing first. If you notice that the cutting speed on your machine is diminished, or you are unable to grind your domes less easily, you may need to replace the wheel. Worn-out diamond wheels feel slightly smooth to the touch.



Sintered diamond wheels will last far longer than electroplated wheels, as the diamond is embedded more deeply into the metal. Sintered wheels can be sharpened by using a dressing stick.

Resin wheels show their wear more directly, with the lighter core showing through the resin at worn points. If you have followed instructions and used all parts of the wheel, these wear marks may be consistent across the wheel. Just because a wheel looks somewhat worn doesn't automatically mean it needs to be replaced. Replace resin wheels only when they no longer seem to be doing their job - or if a tear or hole develops in the resin.

ENJOY
your new
Highland Park CB6V 6-wheel
cabbng machine!

And remember: Practice makes perfect!



Troubleshooting

ISSUE	SOLUTION
Parts are missing or something was damaged during shipment.	Contact us directly at 512-348-8528.
Unit vibrates when running	Try removing the heavier wheels on the machine and see if the vibration goes away. Rotating the wheels on the shaft can sometimes eliminate the problem; if they are unbalanced by even a small amount, it can cause vibration.
Belt squeals when starting up	Belt tension may need to be adjusted
Felt makes rubbing sound when starting up	No fix needed; the felt will become quieter as it gets wet and the material relaxes.
New machine doesn't start, motor hums (non-variable speed)	Turn off the machine immediately and make sure the wheels rotate freely. If the machine is humming and not running, it WILL burn up the motor. If your machine is new, contact your Highland Park Lapidary sales representative. Machines are covered under warranty for one year.
Turned on the machine, doesn't start, no hum	For variable speed motors, there is about a five-second delay as the controller boots up for variable speed drive. If your machine doesn't start after this delay, Make sure the speed control knob is rotated enough that the wheel will start turning. If the dial is on zero, the wheels won't turn
Wheels are slipping when I try to use them.	Check to make sure the nut on the end of the shaft is tight. If the nut is tight, then see the "Changing the Wheels" section of the manual. Most likely you need to add a longer spacer to get the proper shaft extension (1/4") so the nut doesn't bottom out on the threads.
Water flow is weak or doesn't flow.	Check to make sure there is sufficient water in the reservoir. If so, check all the valves. If only one valve is not working, check for debris blocking the flow. The best way to clean it is to remove the needle, then put a little air in the nozzle to blow the debris out. (See "Cleaning Out the Valves"

Warranty Coverage

Machines, Polishers, Diamond Blades & Core Bits and Motors

Highland Park warrants to the original purchaser for a period of one year except as noted, from the date of purchase all products covered by this Warranty to be free of defects in materials and workmanship. This warranty is non-transferable and applies only to the original purchaser.

This Warranty shall not apply to any parts that have been subjected to misuse or improper service, that had been damaged in transit or handling, or that have been altered or repaired by unauthorized representatives. This Warranty does not cover defects caused by or resulting from misuse, abuse, neglect, or damage caused by accident or the failure to provide reasonable maintenance. This Warranty is void if the product or any of its individual components is altered or modified by the purchaser or if the product is used in a manner or with a blade not recommended by the manufacturer.

Any claim arising under this Warranty must be submitted by the original purchaser within the warranty period specified above and shall include proof of purchase. During said warranty period Highland Park shall, at its option, either replace or repair, at no charge to the original purchaser, any parts or components that are found to be defective by Highland Park. Highland Park shall not be responsible for or obligated to pay for freight or other transportation-related costs or expenses in connection with any defective products or components that are either returned to Highland Parks facility or any authorized repair station and/or any replacement products or components that are shipped from Highland Park pursuant to this Warranty.

Parts and labor needed to maintain products and the replacement of components due to normal use are the purchaser's responsibility and are not covered by this Warranty. All products or components replaced under warranty become the property of Highland Park. All replacement parts will be considered to be part of the original product and any warranty on such parts will expire coincidentally with the original Warranty. Replacement part(s) installed by anyone else will be provided without a charge for such replacement part(s), but this Warranty will not apply to labor charges in connection therewith.

IN NO EVENT SHALL ANY LIABILITY UNDER THIS WARRANTY EXCEED THE REPLACEMENT COST OF ANY DEFECTIVE PRODUCT OR COMPONENT THEREOF, AND HIGHLAND PARK SHALL NOT BE LIABLE FOR ANY INCIDENTAL OR CONSEQUENTIAL DAMAGES OR FOR ANY OTHER DAMAGE OR LOSS NOT EXPRESSLY ASSUMED AS SET FORTH HEREIN.

The foregoing constitutes an expressed warranty on the terms set forth above and is the only warranty or warranties applicable to the products it covers. All other warranties, including, without limitation, the implied warranty of merchantability and/or fitness for a particular purpose or use being denied. This limited warranty is expressly in lieu of all other warranties, whether expressed or implied.

Exploded Views

CB6V PARTS LIST #1

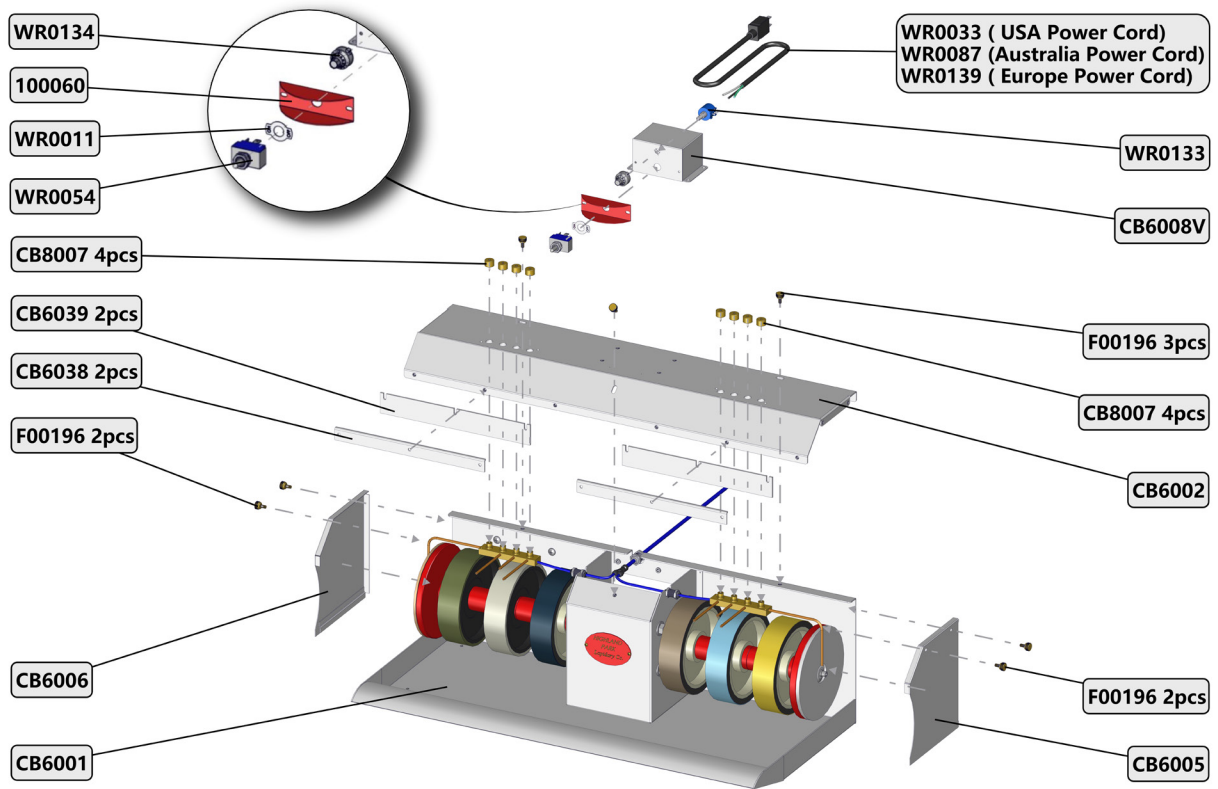

Part Number	Description	Quantity
100060	Toggle Switch Guard	1
CB6001	CB6 Full Frame Assembly	1
CB6002	Top Cover Assembly	1
CB6005	Right Cover Assembly	1
CB6006	Left Cover Assembly	1
CB6008V	CB6V Switch Box	1
CB6038	Wiper Retainer	2
CB6039	Felt Wiper	2
CB8007	Valve Needle Assembly	8

F00196	10-32 x 1/2" Brass Thumb Screw	7
WR0011	On Off Switch Plate	1
WR0033	USA Power Cord	1
WR0054	Heavy Duty Toggle Switch	1
WR0087	Australia Power Cord	1
WR0133	Ohm Potentiometer	1
WR0134	Potentiometer Turn Counter Knob	1
WR0139	Europe Power Cord	1

CB6V PARTS LIST #2

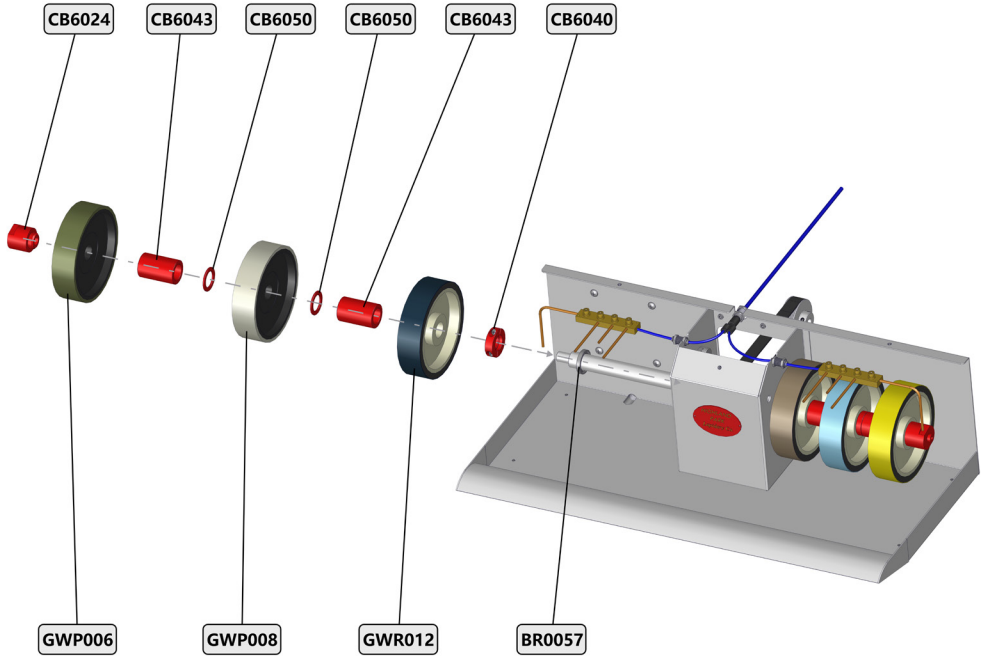

Part Number	Description	Quantity
BR0057	Shaft Seal	1
CB6024	Left Side Disk Adapter	1
CB6040	Split Collar	1
CB6043	2.33" Spacer	2
CB6050	0.098" Spacer	2
GWP006	#80 Grit Plated Balanced 6 x 2 inch Wide Grinding Wheel	1
GWP008	#220 Grit Plated Balanced 6 x 2 inch Wide Grinding Wheel	1

GWR012	#280 Grit Balanced Resin Bond Diamond 6 x 1-1/2 inch Wide Wheel	1
--------	---	---

CB6V PARTS LIST #3

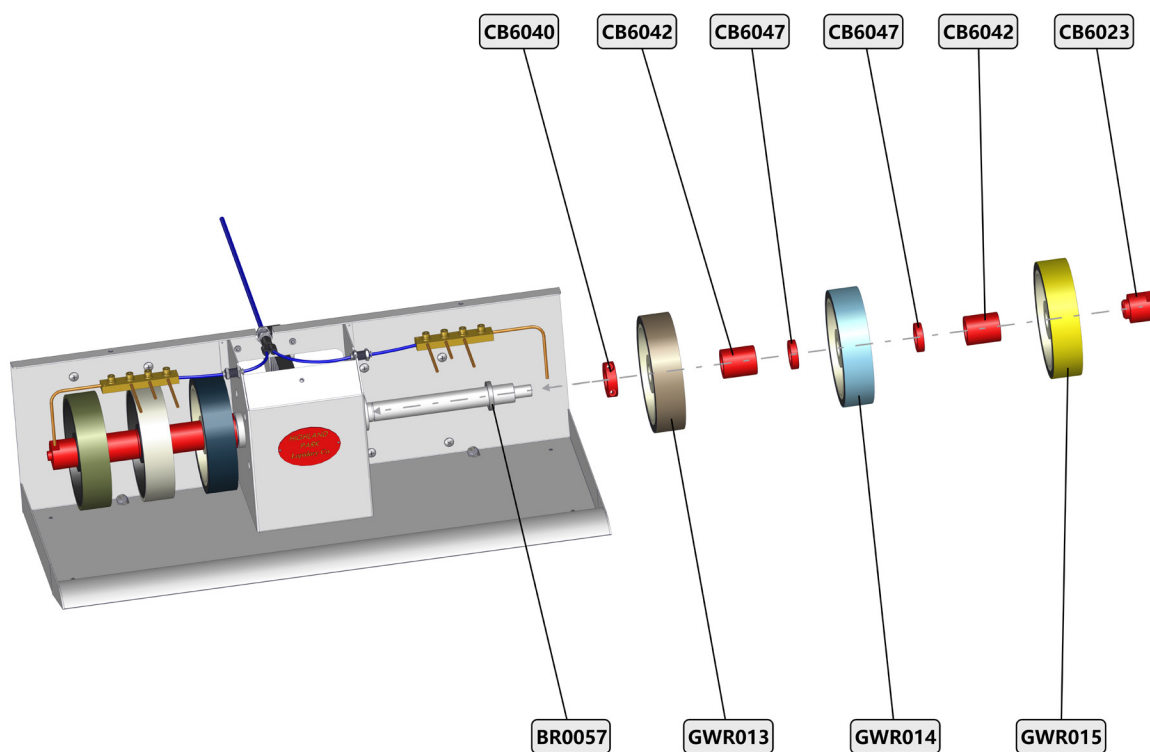

Part Number	Description	Quantity
BR0057	Shaft Seal	1
CB6023	Right Side Disk Adapter	1
CB6040	Split Collar	1
CB6042	1.725" Spacer	2
CB6047	0.354" Spacer	2
GWR013	#600 Grit Balanced Resin Bond Diamond 6 x 1-1/2 inch Wide Wheel	1
GWR014	#1200 Grit Balanced Resin Bond Diamond 6 x 1-1/2 inch Wide Wheel	1

GWR015	#3000 Grit Balanced Resin Bond Diamond 6 x 1-1/2 inch Wide Wheel	1
--------	--	---

CB6V PARTS LIST #4

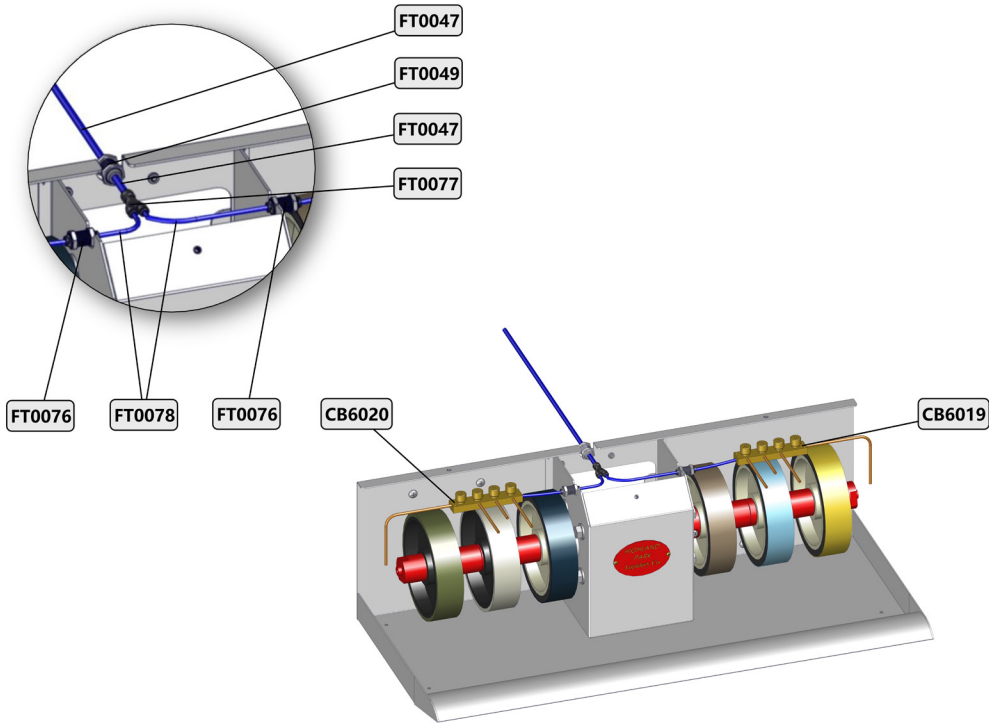

Part Number	Description	Quantity
CB6019	Right Valve Assembly	1
CB6020	Left Valve Assembly	1
FT0047	6mm Poly Tube	1
FT0049	14mm OD 6mm to 6mm QD Bulkhead Fitting	1
FT0076	4mm QD Bulkhead Fitting 12mm OD	2
FT0077	6mm to two 4mm QD Y Fitting	1
FT0078	4mm Poly Tube	2

CB6V PARTS LIST #5

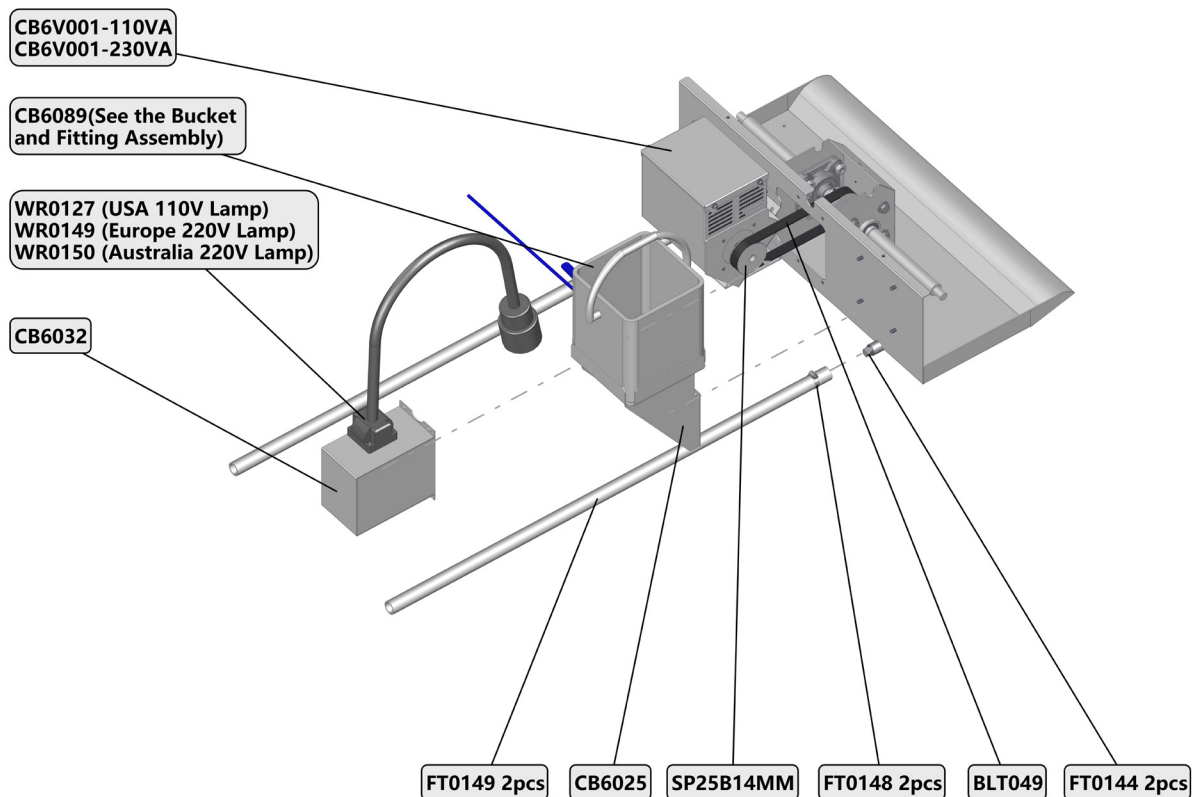

Part Number	Description	Quantity
BLT049	Serpentine Belt	1
CB6025	Bucket Holder Assembly	1
CB6032	Belt Guard Assembly	1
CB6089	Bucket and Fitting Assembly	1
CB6V001-110VA	CB6V Variable Speed Control Drive Module 110V	1
CB6V001-230VA	CB6V Variable Speed Control Drive Module 230V	1
FT0144	3/8 NPT Male Drain Plug SS Stainless Steel	2
FT0148	16-25mm Stainless Hose Clamp	2
FT0149	22 ID 27 OD PVC Hose	2
SP25B14MM	CB6V Motor Pulley	1

WR0127	USA 110V LED Lamp	1
WR0149	Europe 220V LED Lamp	1
WR0150	Australia 220V LED Lamp	1

CB6V PARTS LIST #6

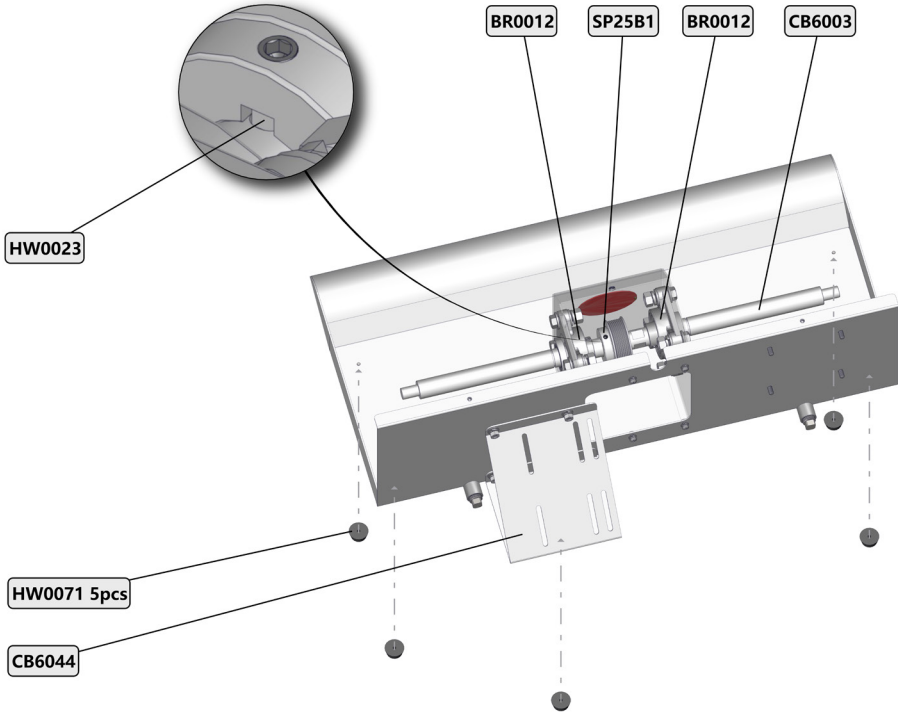

Part Number	Description	Quantity
BR0012	UCF205-100D1 Bearing	2
CB6003	Main Shaft	1
CB6044	Motor Mount Assembly	1
HW0023	1/4 Key Stock	1
HW0071	Rubber Feet	5
SP25B1	Main Shaft Pulley	1

CB6V VARIABLE SPEED MOTOR ASSEMBLY

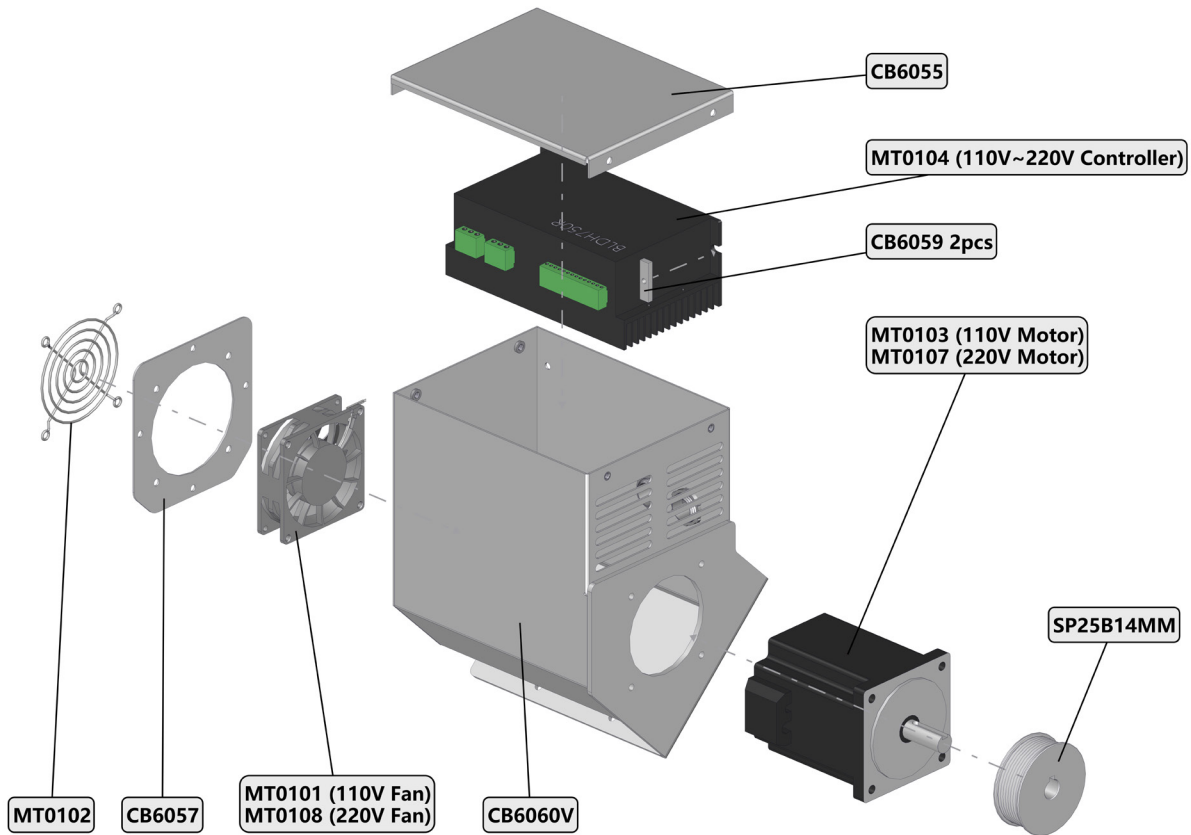

Part Number	Description	Quantity
CB6055	CB6V Brushless Motor Mount	1
CB6057	CB6V Fan Bracket	1
CB6059	CB6V Controller Retainer Nut	1
CB6060V	CB6V Variable Speed Box Weld Assembly	1
MT0101	Cooling Fan 110V	1
MT0102	Muffin Fan Guard	1
MT0103	110V Brushless Motor	1
MT0104	110V~220V Brushless Controller	1
MT0107	220V Brushless Motor	1
MT0108	Cooling Fan 220V	1
SP25B14MM	CB6V Motor Pulley	1

CB6V BRUSHLESS DC MOTOR ASSEMBLY SCREWS AND FASTENERS

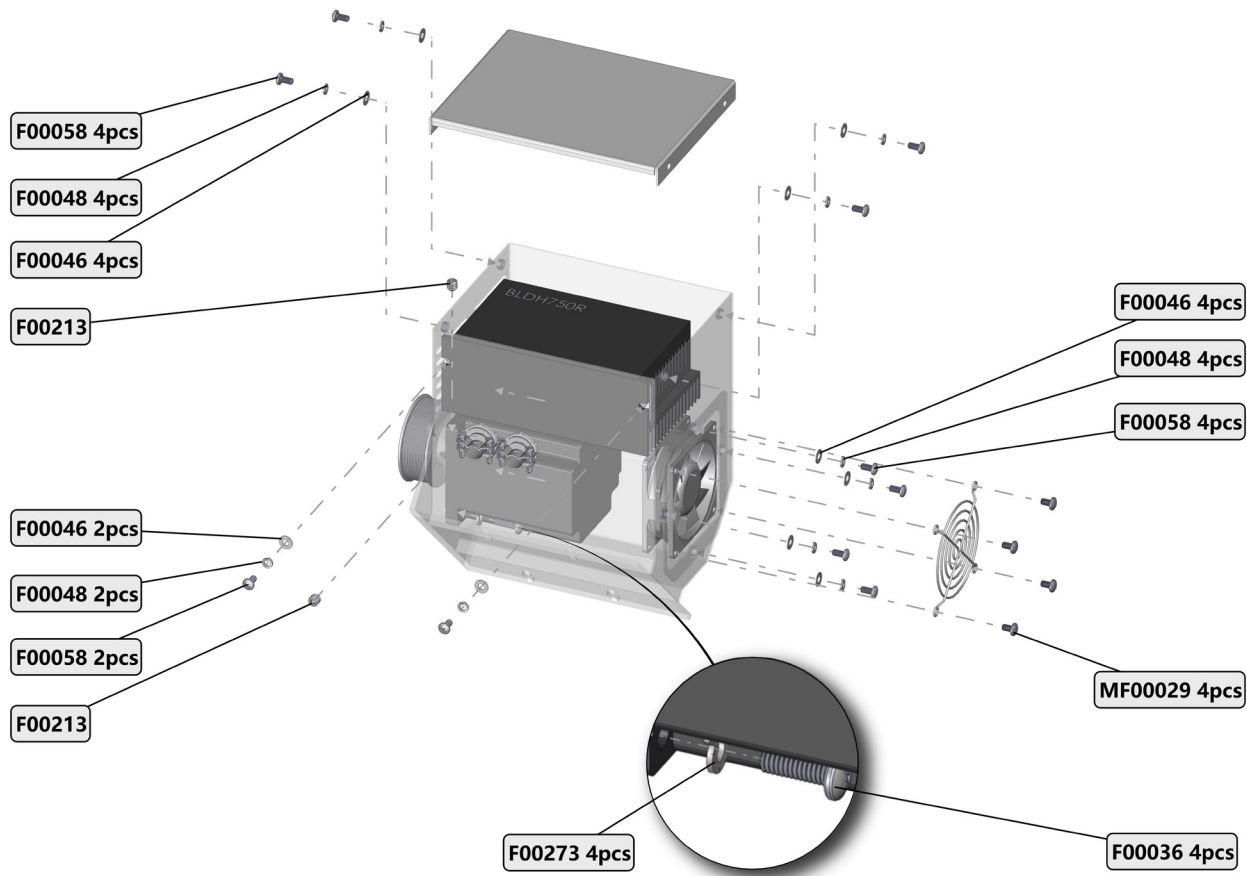

Part Number	Description	Quantity
F00036	1/4-20 x 3/4 PHP Pan Head Phillips SS304	4
F00046	10-32 Flat Washer 304SS	10
F00048	10-32 Lock Washer 304SS	10
F00058	10-32 x 3/8 PHP Pan Head Phillips SS304	10
F00213	5/16-18 x 5/16 SS Set Screw 304SS	2
F00273	1/4-20 Lock Washer 304SS	4
MF00029	M5-0.8 x 8mm PHP Pan Head Phillips SS304	4

CB6V BUCKET & FITTING ASSEMBLY

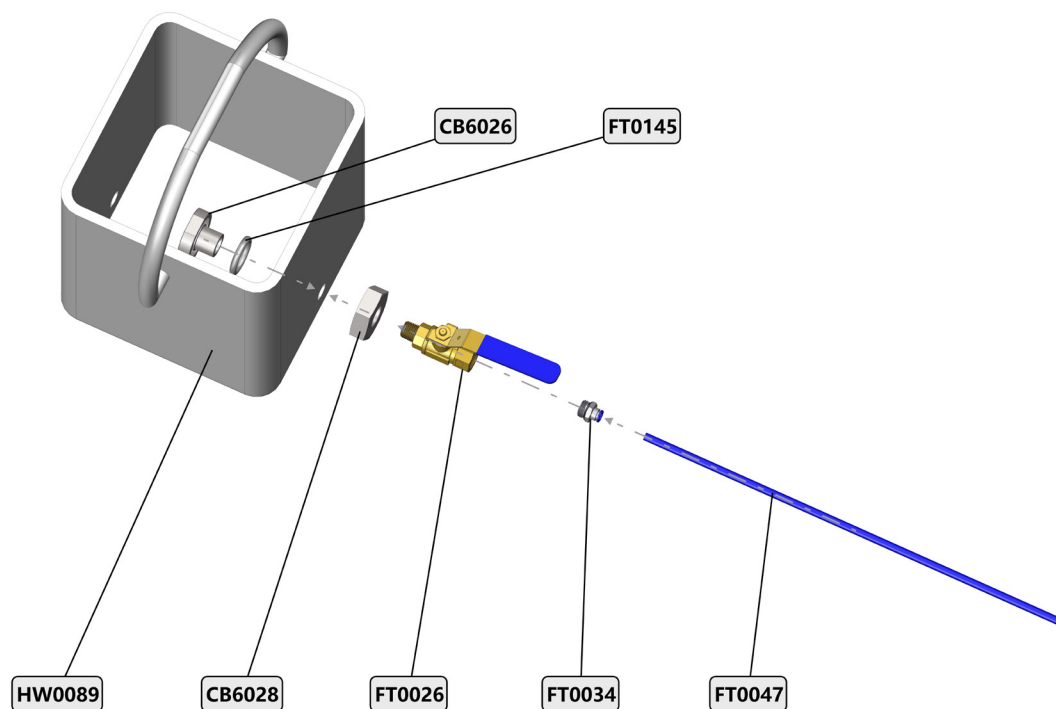

Part Number	Description	Quantity
CB6026	Reservoir Fitting	1
CB6028	Reservoir Nut	1
FT0026	1/4 M to 1/4 F Ball Valve	1
FT0034	1/4 NPT male to 6mm QD Fitting	1
FT0047	6mm Poly Tube	1
FT0145	32mm OD, 22mm ID, 5mm thick O-ring	1
HW0089	7 inch Square Water Bucket	1

CB6V POLISH BACKER PADS

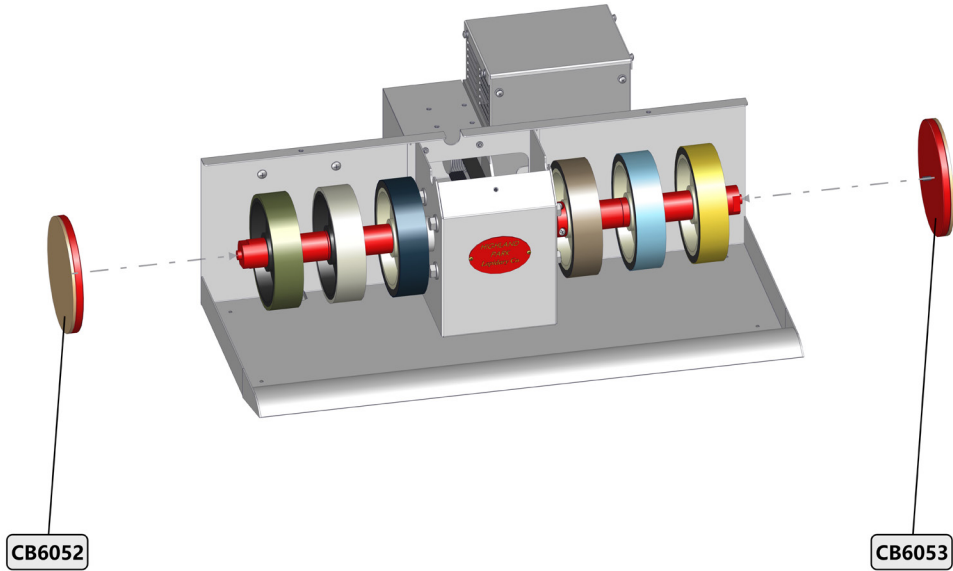

Part Number	Description	Quantity
CB6052	CB6 Left Hand Polish Backer Plate Assembly	1
CB6053	CB6 Right Hand Polish Backer Plate Assembly	2

CB6V SCREWS & FASTENERS #1

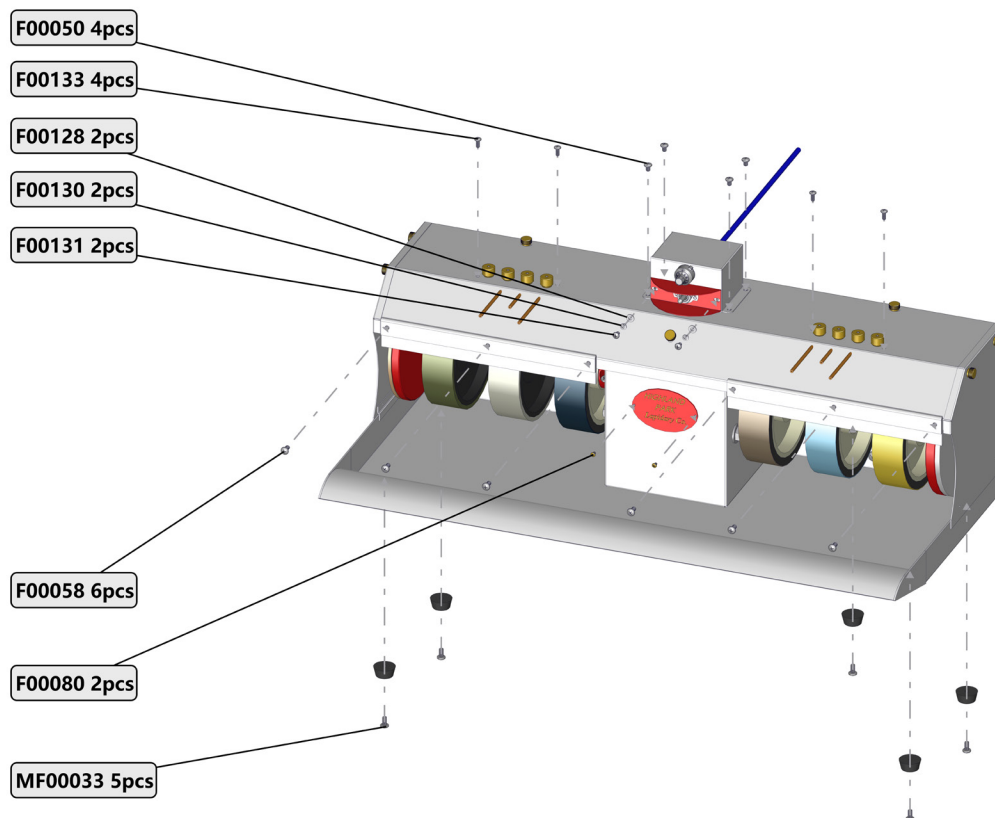

Part Number	Description	Quantity
F00050	10-32 x 1/4" PHP Pan Head Phillips 304SS	4
F00058	10-32 x 3/8" PHP Pan Head Phillips 304SS	6
F00080	4-40 3/16" PHP Pan Head Phillips Brass	2
F00128	8-32 Flat Washer 304SS	2
F00130	8-32 Lock Washer 304SS	2
F00131	8-32 x 1/4" PHP Pan Head Phillips 304SS	2
F00133	8-32 x 3/8" PHP Pan Head Phillips 304SS	4
MF00033	M5-0.8 x 10mm PHP Pan Head Phillips 304SS	5

CB6V SCREWS & FASTENERS #2

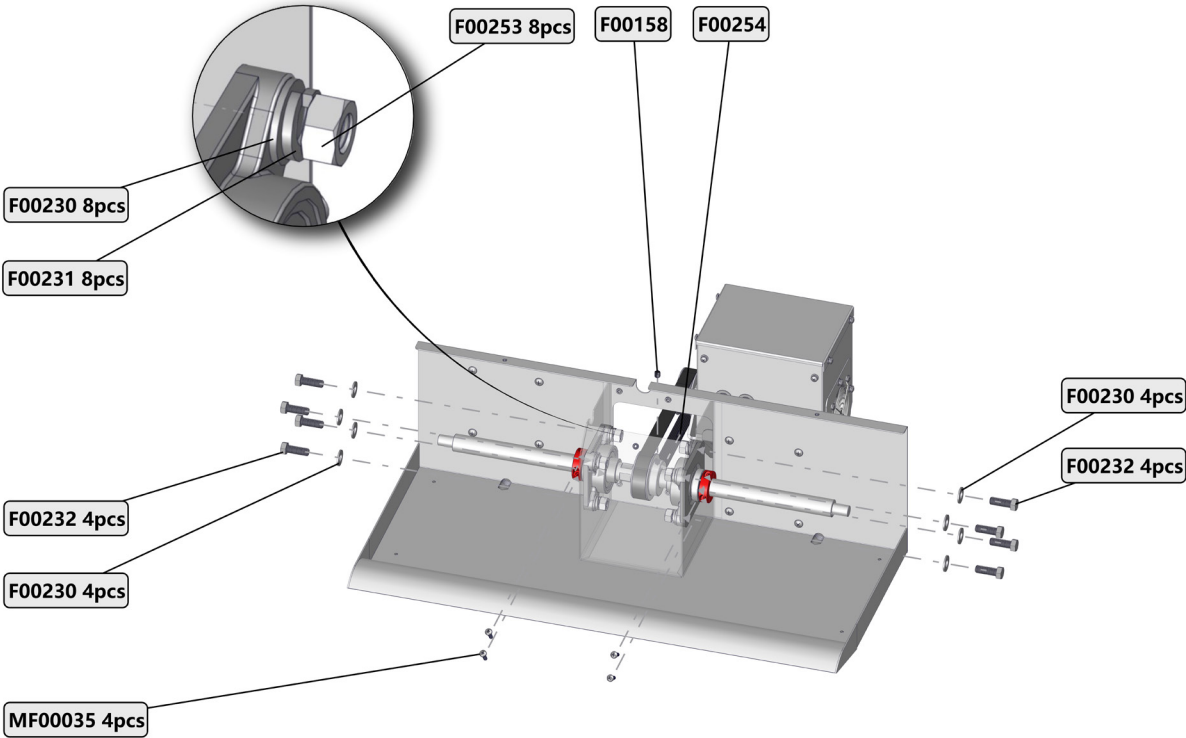

Part Number	Description	Quantity
F00158	5/16-18 x 3/8" Set Screw 304SS	1
F00230	7/16 Flat Washer 304SS	16
F00231	7/16 Lock Washer 304SS	8
F00232	7/16-14 x 1-1/4" HHCS Hex Bolt 304SS	8
F00253	7/16-14 Nut 304SS	8
F00254	5/16-18 x 1/2" inch Set Screw 304SS	1
MF00035	M5-0.8 x 20mm PHP Pan Head Phillips 304SS	4

CB6V SCREWS & FASTENERS #3

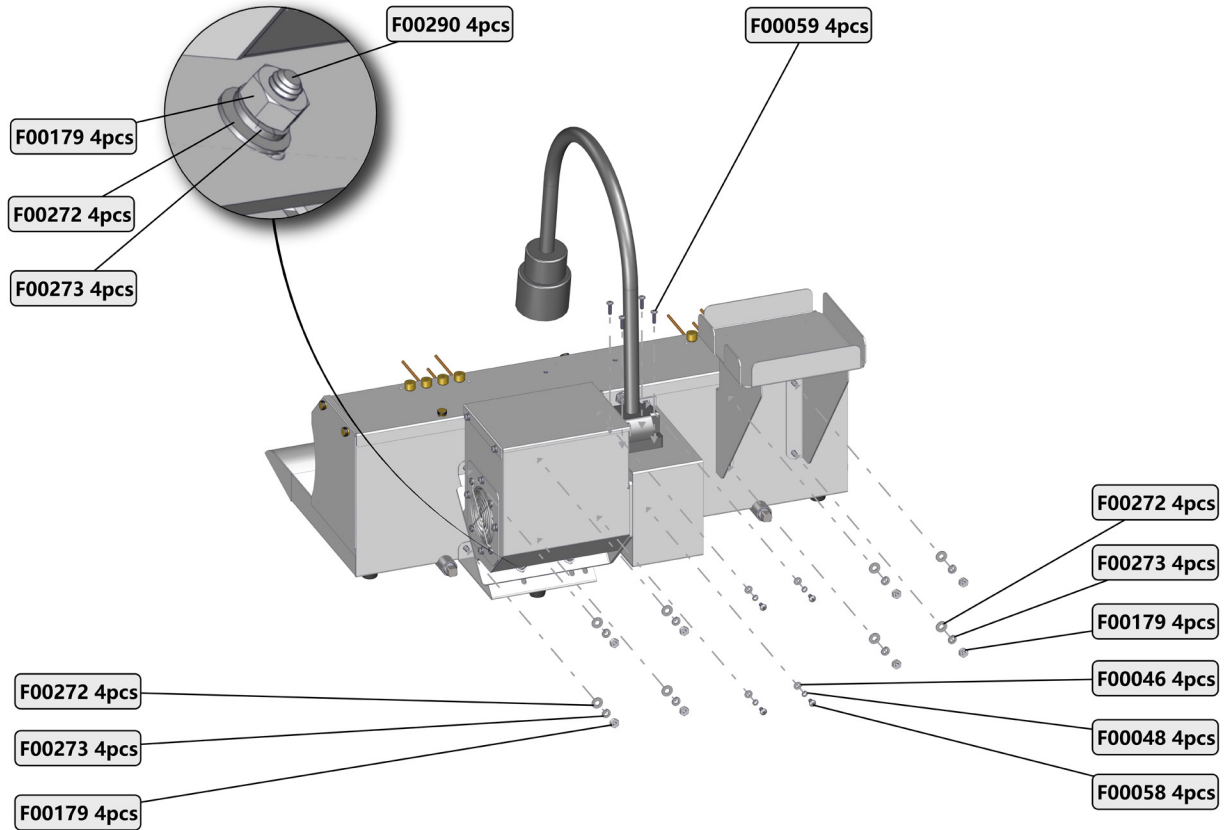

Part Number	Description	Quantity
F00046	10-32 Flat Washer 304SS	4
F00048	10-32 Lock Washer 304SS	4
F00058	10-32 x 3/8" PHP Pan Head Phillips 304SS	4
F00059	10-32 x 5/8" PHP Pan Head Phillips 304SS	4
F00179	1/4-20 Hex Nut 304SS	12
F00272	1/4-20 Flat Washer 304SS	12
F00273	1/4-20 Lock Washer 304SS	12
F00290	1/4-20 x 3/4" CHCS Carriage Head Bolt 304SS	4

CB6V 6" Wheel Cabbing Machine Owner's Manual & Operating Instructions







www.hplapidary.com

CONTACT US

info@hplapidary.com
512-348-8528

FOLLOW US

-  Highland Park Lapidary Co.
-  @hplapidary
-  Highland Park Lapidary
-  @highlandparklapidary

LIFE'S TOO SHORT TO CUT UGLY ROCKS!

HIGHLAND PARK LAPIDARY LIVE EVENTS

Mondays, Wednesdays, Thursdays,
Fridays and Saturdays
Starts at 7:00 PM EST

