



Owner's Manual and Operating Instructions

**MODEL**

**HT-14**

**14-INCH SLAB SAW**

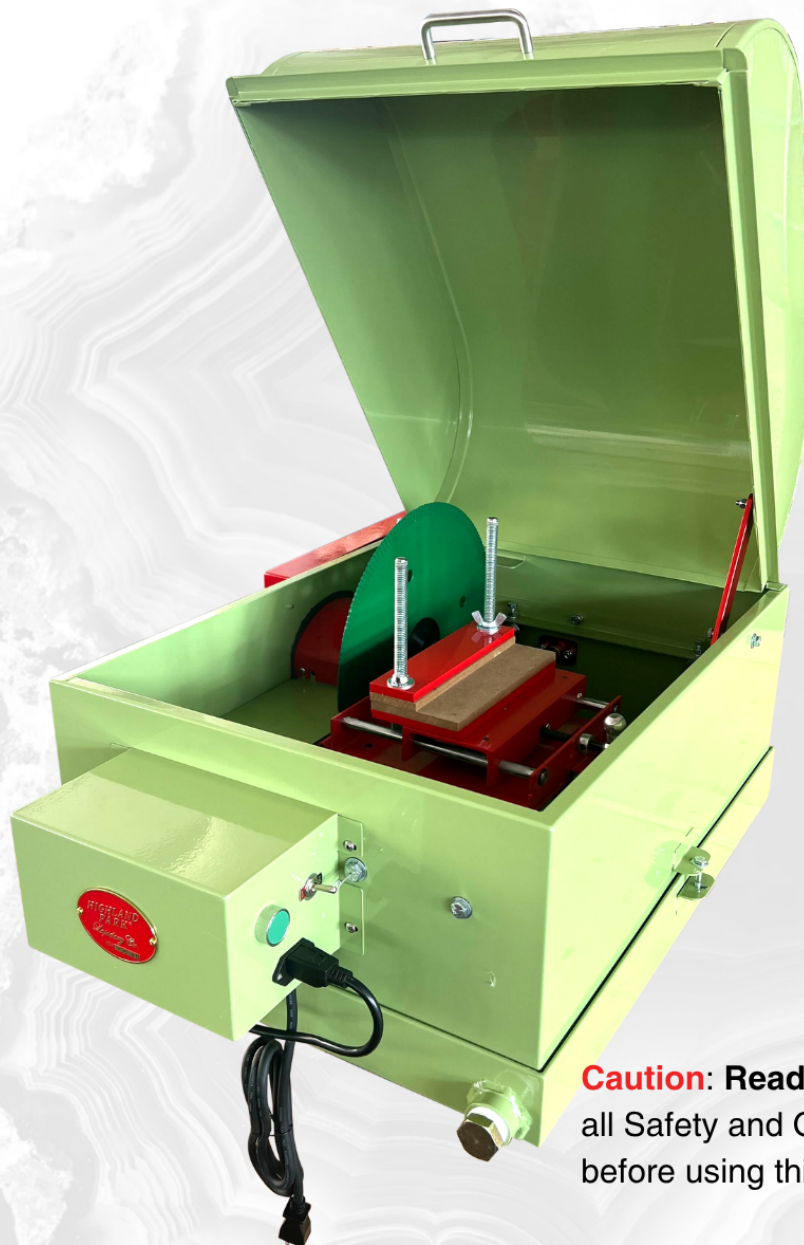

**Caution:** Read and Understand all Safety and Operating Instructions before using this equipment



# Introduction

---

THANK YOU for selecting the Highland Park Lapidary HT-14 Slab Saw! Our dedicated team is confident that you will be pleased with your purchase. Highland Park Lapidary takes pride in producing top quality, highly dependable products for both hobby and commercial lapidary users throughout the world.

Your new slab saw will arrive assembled, however the motor ships separately and will be installed once you set up your machine. IMPORTANT NOTE: Lapidary saws MUST have coolant added prior to operation. Your saw is not shipped with cutting oil installed in the saw box. You must add this according to these instructions prior to operation.

Prior to operation please do a quick check to confirm all the necessary items are included. This will also serve to begin to familiarize you with the various operating parts of the saw:

Operated correctly, your HT-14 Slab Saw will provide you with years of quality service, and mountains of beautiful rocks. To help familiarize you with the features, maintenance and safe operation of the machine, we have included this owner's manual.

Please take the time to acquaint yourself with the HT-14 Slab Saw by reading and understanding this manual. If you have questions concerning your HT-14 Slab Saw, our customer service staff is waiting to help you - call 512-348-8528.

# Table Of Contents

---

<b>Product Safety</b> .....	1
<b>Highland Park HT14 Specifications</b> .....	3
<b>Setting Up Your Machine</b>	
Tools Needed.....	5
Unpacking the Saw	
Selecting a stable work table.....	5
Installing the Motor.....	5
Installing the Belt Guard.....	6
Installing or Changing the Blade	
Installing the Blade.....	7
Removing the Blade.....	8
Connecting the Motor Power.....	8
Putting Coolant in the Tank.....	9
Oil Selection.....	10
<b>Running Your Machin</b>	
Ready to Run Checklist.....	10
Loading a Stone in the Vise.....	10
How to Break In Your Wheels.....	11
Alternative vises.....	13
Starting and Running the Saw.....	15
Changing the Oil and Reinstalling the Blade.....	16
<b>Maintaining Your Machine</b>	11
Carriage Adjustment.....	17
Arbor Alignment.....	18
<b>Warranty</b> .....	19
<b>Troubleshooting Your Machine</b> .....	20
<b>Exploded Views And Parts Lists</b>	
HT-14 Main Components #1.....	21
HT-14 Main Components View #2.....	22
HT-14 Main Components View #3.....	23
HT-14 Main Components View #4.....	24
HT-14 Switch Box.....	25
HT-14 Full Carriage Assembly.....	27
HT14 Vise Assembly.....	29
HT-14 Screws & Fasteners #1.....	30
HT-14 Screws & Fasteners #2.....	31
HT-14 Screws & Fasteners #3.....	32
HT-14 Screws & Fasteners #4.....	33

# Safety Precautions

The beautifully engineered Highland Park Lapidary Model HT14 Slab Saw has an improved overall design. Improvements include a heavy gauge steel main body, a precision arbor system with heavy duty cast iron pillow block bearings and adjustable arbor mount assembly. The carriage has easily adjustable roller bearings that maintain smooth movement on the hardened steel rails producing precise smooth cuts. All of our Slab Saws have our Interlock Control box which insures that the saw cannot accidentally start and cause injury or throw oil all over your work area. Also the Saw has a large drain port in the machine tank for easy cleaning. The Model HT14 was built with the lapidarist in mind, designed to give comfort, high performance, and convenience to the user.

**Used incorrectly, all electrical equipment carries some risk. To eliminate danger to either yourself or the machine, please read and follow all safety, operating and maintenance instructions!** Failure to *read, understand and follow* these instructions could result in injury or death to you or others, or result in damage and/or reduced equipment life.

## EYE PROTECTION

Safety glasses should always be worn when operating this machine. Regular eyeglasses do not provide proper protection and may not prevent eye injury.

## HEARING PROTECTION

To reduce the possibility of hearing loss, always use hearing protection when operating this machine.

## PROTECT YOUR LUNGS

An NIOSH certified dual cartridge respirator for dust and oil (P95) should be always worn when running the machine, because oil mist and rock dust can be hazardous to your health.

**WARNING:** *Some materials contain minerals or metals that can be more toxic. For instance, metallic ores may contain some toxic materials, so before grinding and polishing any unfamiliar material, make certain that it will not produce toxic fumes or dust. Extra protection may be necessary for more toxic materials.*

## AVOID LOOSE CLOTHING AND HAIR

Do not wear loose clothing, gloves, neckties, rings, bracelets or other jewelry that may be caught in moving parts.

Wear protective hair covering to contain long hair. Non-slip footwear is also recommended.

### **DO NOT OPERATE MACHINE WITH GUARDS REMOVED**

To prevent injury, never operate the machine without the guards in place.

### **CONNECTING AND DISCONNECTING POWER**

- **DISCONNECTING** The machine should always be disconnected (unplugged) before servicing or changing the oil or the blade.
- **CONNECTING - REDUCE THE RISK OF UNINTENTIONAL STARTS** Make sure the ON/OFF switch is in the OFF position before plugging in the machine.

### **ELECTRICAL SAFETY**

Never touch electrical wires or motor components while the motor is running. Exposed, frayed or worn electrical wiring and plugs can be sources of electrical shock that could cause severe injury or burns.

- If an extension cord is used, it must not be longer than 12 feet and must be at least 12 gauge wire with a ground.
- Use this tool only with the proper power source 120V 60 Hz.
- If the wiring becomes damaged or frayed, replace it immediately.
- Do not allow water to come in contact with electrical components, and do not connect or disconnect the power with wet hands.

### **ROTATING OR MOVING PARTS**

Keep hands, feet, hair, and clothing away from all moving parts to prevent injury. Never operate the motor with covers, shrouds or guards removed.

### **KEEP WORK AREA CLEAN**

- Cluttered work areas invite accidents. **Keep your work area clean and organized.**
- **DO NOT USE IN DANGEROUS OR HAZARDOUS ENVIRONMENTS** Do not operate equipment in dangerous or hazardous environments. Do not use power tools in damp or wet locations nor expose them to rain. Always keep the work area well lighted. Always work in a well-ventilated area.
- **KEEP CHILDREN AWAY** All visitors and children should be kept at a safe distance from the work area.

### **WORK METHOD**

- **USE THE RIGHT TOOLS TO SERVICE THE SAW:** Do not force a tool or an attachment when servicing or operating this power tool. Use the correct tools for service or adjustments.
- **DO NOT OVERREACH:** Keep proper footing and balance at all times by not overreaching.
- **DO NOT OPERATE A TOOL WHEN TIRED:** When tired, take a break and relax.
- **NEVER LEAVE A TOOL RUNNING UNATTENDED – TURN POWER OFF:** Always turn the tool off when leaving the work area or when work is finished.

### **MAINTAINING THE MACHINE**

- **CHECK FOR DAMAGED OR WORN PARTS** Before using the machine, check for damaged parts or wires. A guard

or any other part that is damaged or worn should be replaced. Regularly check moving parts for proper alignment or binding.

- **USE RECOMMENDED ACCESSORIES AND PARTS** Consult the owner's manual for recommended accessories and parts. Using improper parts and accessories may increase the risk of personal and/or bystander injury.

## Specifications

<b>Slab Saw Model</b>	HT-14
<b>Machine Weight</b>	140 lbs
<b>Motor Horsepower</b>	1/2 HP
<b>Motor Voltage</b>	110V 50/60Hz Single Phase
<b>Motor RPM</b>	1725 RPM
<b>Arbor Shaft</b>	5/8"
<b>Blade Capacity</b>	14" (304 mm) diameter
<b>Workpiece Size</b>	5-1/2 x 7 inch Cross Section
<b>Crossfeed Length</b>	4.7 inches
<b>Height</b>	18.8 inches
<b>Width</b>	23 inches
<b>Length</b>	41 inches

### Highland Park HT-14 Specifications:

**ARBOR SHAFT** – 4140 Alloy Steel machined to 3/4 inch bearing diameter. 5/8 inch diameter for blade arbor

**BLADE FLANGES** – Steel 3 inch outside

**BLADE** - GreenLine Agate Eater sintered diamond blade

**SAFE START SYSTEM** - Interlock Contactor Control System eliminates the risk of accidental startup

**AUTOMATIC CUT-OFF SWITCH** – Shuts off the machine at the end of the cut, Adjustable for length of cut

**POWERFEED** – Approximate workpiece feed rates 10 inches per hour, .166" inches per minute

**SPLIT NUT DRIVE** – Engages carriage with powerfeed screw. Released by a flip of the handle for quick carriage return

**PRECISION CARRIAGE** – Carriage rides on precision-ground hardened 3/4” steel rails

**CROSSFEED WAYS** – 1/2 inch precision ground steel

**SAW BOX** – Welded 16 gauge steel.

**V-BELT** – Connects motor to the saw blade

**VISE** – Steel vise jaws – Maximum workable jaw opening 5 1/2 x 7 inches Crossfeed travel of vise assembly 4.7”

**MOTOR** – 110 volt NEMA 56 frame 1/2 HP motor with overcurrent protection and both start and run capacitors ((230 volt 50 Hz also available)

## Setting Up Your Machine

Your new slab saw will arrive assembled and precision aligned. However, the motor ships separately and will be installed once you set up your machine. **IMPORTANT NOTE: Lapidary saws MUST have coolant added prior to operation. Your saw is not shipped with cutting oil installed in the saw box. You must add this according to these instructions prior to operation.**

Prior to operation please do a quick check to confirm all the necessary items are included. This will also serve to begin to familiarize you with the various operating parts of the saw.

- Check for any shipping damage to the shipping box or saw itself. If none is found proceed with verification checks. If physical damage is found to the saw please contact us immediately and note it when you are signing for the receipt of shipment.
- Visually inspect your saw for any loose fasteners or damage. Your saw was carefully assembled and quality checked prior to shipment. However, during shipment and handling sometimes rough treatment can cause loosening of fastener. It is a good practice to visually inspect your machine as you are using it periodically to notice any potential issues.
- Please read this operating manual thoroughly prior to operation of the saw. It is very important that you understand the operation of your new saw, safeguards, and proper operation before proceeding to actual use of the machine. Failure to read and understand the operating instructions could result in unsafe operation and damage to the machine and may result in voiding your warranty. Properly used, your new slab saw will deliver many years of worry-free service.

## TOOLS NEEDED

- #2 Phillips screwdriver
- Medium-sized adjustable wrench, 10" long
- Straight edge ruler or a Level

## UNPACKING THE SAW

The HT-14 Slab Saw weighs approximately 140 lbs. (63.6 kg). Take care when lifting the unit from the box, as improper lifting might cause personal injury or cause damage to the machine.

Your Highland Park HT-14 Slab Saw has been shipped from the factory thoroughly tested and inspected. Choose a place in your workspace for your saw that allows adequate working space and has a convenient power outlet. Avoid using an extension cord; it's much safer to connect the machine directly to a wall power outlet.

## SELECTING A STABLE WORK TABLE

Place the saw on a flat surface so the saw will not wobble or rock during use. For safe and proper operation the HT-14 Slab Saw must be set on a strong and secure table or workbench. The work surface should be flat and level. A level work top is important so that coolant fluid in the saw box is uniform depth.

The physical strength of the work table or bench is important, since the saw weighs approximately 140 pounds without oil or rock included. A powerful 1/2 H.P. motor powers the saw. While the machine is very well balanced for smooth operation, some vibration will be present during operation. For these reasons please be certain that the mounting surface is strong enough to support your machine.

## INSTALLING THE MOTOR



1. This saw has a 1/2 HP, 1750 RPM motor with a size NEMA 56 frame. Unbox the motor and then remove the two screws on the back of the saw motor mount bracket.

- Put the belt around the motor pulley and arbor pulley while holding the motor at an angle.



- Lift the motor and then align the holes of the motor plate (3a) to the motor mount bracket, and put the screws through the slots on the motor plate back into the motor mount bracket (3b). Don't tighten the screws yet!
- Use a straight edge to align the pulleys by sliding the motor to the left or right until the pulleys are aligned and then tighten the two screws into the motor mount bracket. Tighten the two screws holding the motor, but don't overtighten them as this can strip the threads
- Loosen the motor adjustment screws (4a). Adjust the two belt tension bolts on the lower part of the motor plate to obtain the correct belt tension. Do not overtighten the belt, as this can cause unnecessary bearing wear. The belt should deflect about  $\frac{1}{2}$ " to 1" when you squeeze it lightly (4b). Excess belt tension can cause increased wear on the bearings.

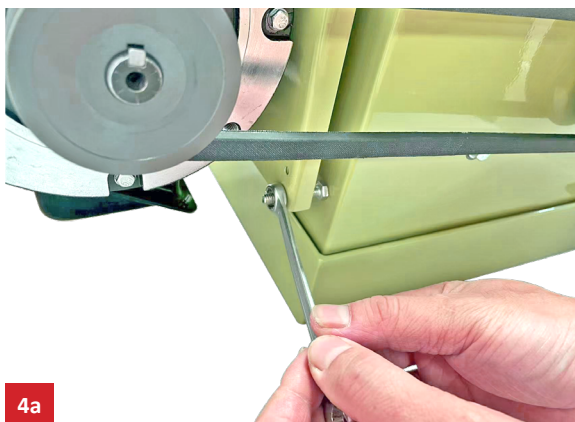

### INSTALLING THE BELT GUARD

Place the belt guard over the belt, motor pulley, and frame. Install the two mounting screws and tighten securely



## INSTALLING OR CHANGING THE BLADE

Installing or changing the blade is easy on your Highland Park Lapidary Model HT14

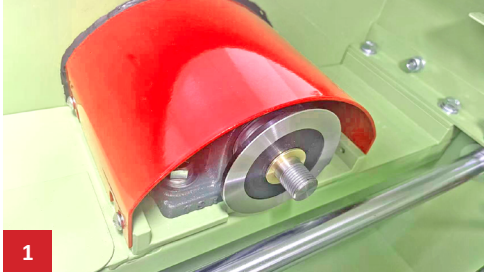

1. Carefully clean both arbor flanges and the exposed end of the arbor shaft and wipe both sides of the blade off carefully.
2. Be certain the blade bushing stays in place in the center of the blade, and does not slip.
3. Put the blade bushing on. Locate the blade properly on the bushing. Put the second flange on with the recess towards the blade. Slide it on, not allowing the blade to move, until the flange is against the face of the blade. Hold it firmly while putting the arbor nut in place, not letting the blade wobble.

4. Rotate the blade by hand to verify that the blade is turning true, not wobbling either front to back or side to side. If it isn't turning true, take the arbor nut and flanges back off and make sure that the blade and blade bushing are in the correct position.
5. Once the blade is running true, tighten the arbor nut. Don't over-tighten the arbor nut, because doing so may damage the flanges and cause the blade to not run true.

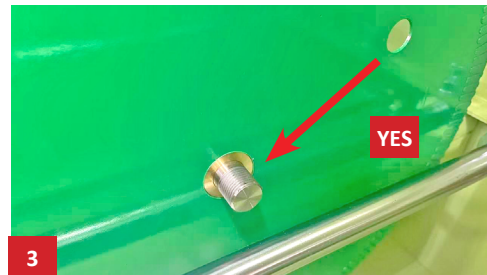

## REMOVING THE BLADE

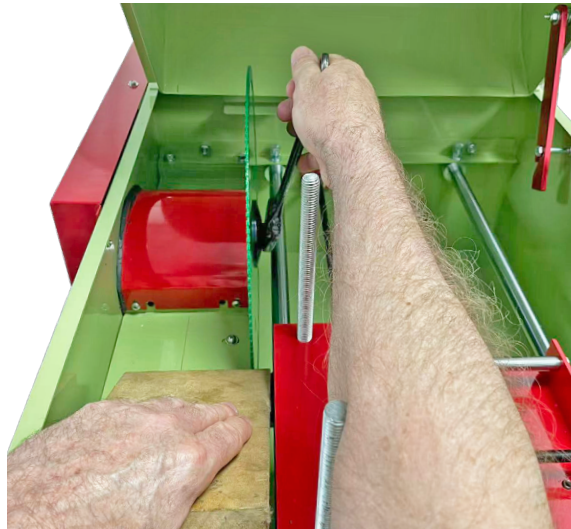

1. Put a wrench on the arbor nut and push a piece of wood against the front edge of the blade. Put pressure directly in line with the blade, not side pressure as this can bend the blade.
2. Turn the arbor nut counterclockwise, when it loosens you should be able to unscrew it easily by hand.
3. Remove the flange, the blade and blade bushing.
4. Inspect the blade flanges for damage. If they show signs of damage, replace them.
5. Clean all the parts. Now you are ready to install a new blade!

## CONNECTING THE MOTOR POWER

You will need to connect the motor power cord to the right side of the switch box. With the switch box unplugged, insert the motor power cord plug into the outlet on the right side of the switch box which is mounted on the front of the saw. The current overload breaker protects the motor if a rock comes loose and stops the blade. If the current overload breaker trips, it will pop out. It can be reset by turning off the power and pushing the overload breaker back in.



## PUTTING COOLANT IN THE TANK

Your saw will require approximately 1-1/3 gallons of cutting oil for the initial fill. As you operate the saw, some oil will be lost in normal operation, as some of it will cling to the stones as they are removed from the saw after cutting. For this reason it is important that you periodically check the level of oil on the saw blade to confirm proper oil depth is present.

You may want to install a ball valve on your drain first, because it will make it much easier to drain the oil when you are changing the oil in the future. First, make sure your machine is level on a stable work surface. If the machine is not level, then it may cause oil to spill over the edges of the tank onto your work table.

Oil is added by simply pouring it into the saw box. (Make sure that the drain plug is in place or that the drain valve is closed before adding oil). You can add one gallon before beginning to check the oil level on the blade. After one gallon has been added, continue to add oil while monitoring the level on the blade.

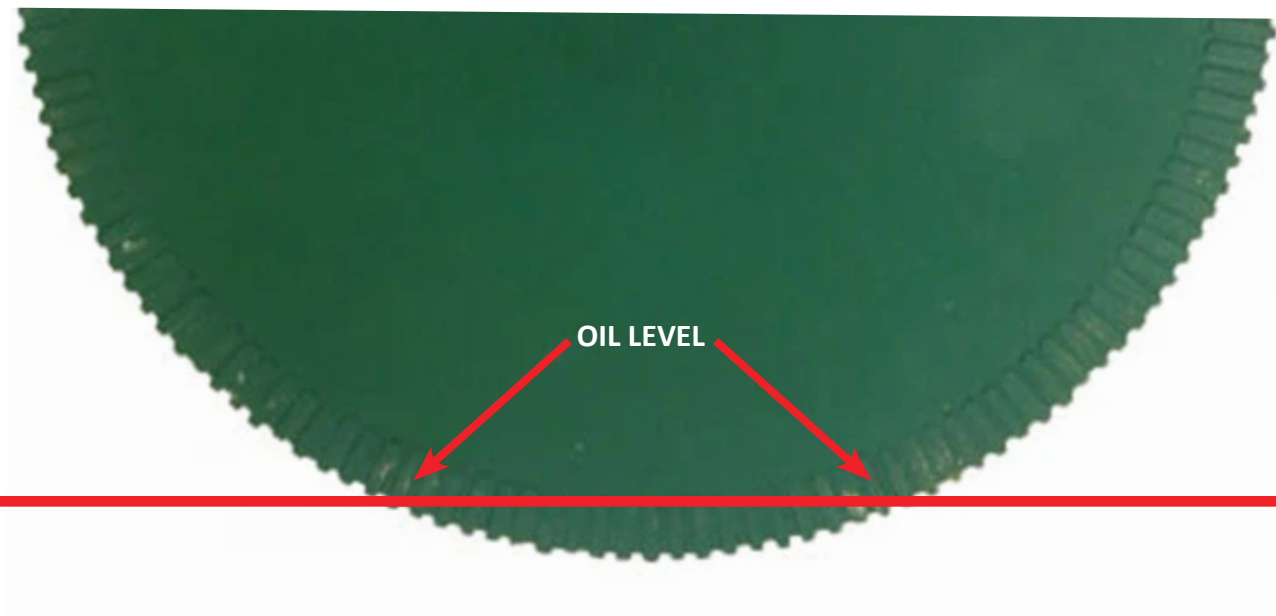

Your target is to have the bottom of the blade immersed about  $\frac{1}{2}$ "- $\frac{5}{8}$ " into the oil initially and to MAINTAIN THIS LEVEL during the use of the saw. If you do not have sufficient oil, it can cause the blade and the stone to get overheated and damage one or both. Additionally, it is not good to overfill the saw too much as this can cause oil to leak out onto the floor.

You may find it helpful to carefully turn the blade a bit by hand to confirm the oil level.

**Caution!** Even with the Highland Park SAFE START SYSTEM, which prevents accidental start-up of the saw, we recommend that you unplug the unit prior to adding oil.

## OIL SELECTION - Low Viscosity Pure Mineral Oil is Best!

Mineral Oil - When running a powerfeed slab saw the best choice for cutting fluid is a viscosity of 6-7cst @40deg C, pure mineral oil. HP Coolcut™ Oil (SKU: CC0501) is the optimal cutting oil based on our extensive research and testing. While there are many other sources for mineral oil to be found, most of these are in the 15-20cst range, which is much thicker and will increase the heat generated in the cutting process. This increased heat and friction will cause the blade to get dull more quickly and if not sharpened more frequently, may cause dishing and will put more stress on the feed components and bearings.

### Bad Ideas

Bad Ideas - Unfortunately there are still bad recommendations to be found on social media: Diesel Oil, Kerosene, Hydraulic Oil, Antifreeze, Water Soluble Oils and viscosity thinners are all a bad idea and will void your warranty. Most of these are both health risks and many are fire risks. We personally know of a number of people who lost their entire shops to fire due to running the wrong coolant.

# RUNNING YOUR MACHINE

### Ready to Run Checklist:

- The saw is secure on the work table or bench.
- Install motor belt and belt guard
- Install diamond blade.
- Plug motor into switchbox
- Confirm proper oil level in the saw box.
- Close hood.
- Confirm power switch in off position.
- Plug in electrical cable.

### PUTTING A ROCK IN THE VISE

1. **Position the Carriage for Loading** -Open the hood and disengage the carriage feed lever from the carriage drive screw.
2. This lever is near the back right corner of the carriage, it is pulled forward to disengage the carriage feed allowing the carriage to be moved manually. It must be held forward to move the carriage, but *only pull the*

*lever far enough to disengage the feed nut.* Pulling it forward more than necessary will begin to stretch the feed engagement spring. Now that the feed nut is disengaged, you can pull the carriage forward to the front of the saw.

3. This is the proper position of the carriage for loading a new rock to be cut.
4. This is the proper position of the carriage for loading a new rock to be cut. Select your stone to be cut- The maximum size rock cross section that can be cut on your HT-14 slabs saw is about 5.5" X 7". Rough lapidary material varies considerably in size and shape: you will find some rocks easy to grip in the vise and others will be more difficult. Rocks that are difficult to secure in the vise include those with very smooth rounded surfaces.
5. **Load the stone in the vise** - Unscrew the thumb screws allowing the top bar on the vise to be raised to accommodate the rock to be cut. Lower the slab vise bar so that it contacts the rock and tighten the thumb screws securely.
6. **Check to be sure the stone is secure** - After securely clamping the stone in the vise, you should not be able to move it easily. If it moves, then you must tighten the thumb screws more or reposition the workpiece to get a better, more secure grip. Additionally, adding shim material if necessary can provide secure contact between the rock and the clamping surfaces of the vise. It may be necessary to use pliers or another tool to tighten the thumb screws.
7. **Check the clearance**- Make sure that the stone doesn't extend below the vise platform. Look underneath the carriage at the position of the rock in relation to the arbor nut and flange. In the photo at right, as the rock is being loaded, it's clear that some portion of the rock will extend below the wood on the lower vise jaw. This check should be done each time you load the stone to prevent damage to the saw. Always use care to ensure that contact does not occur between the rock and the arbor nut or flange. Such contact can damage your flanges and blade.

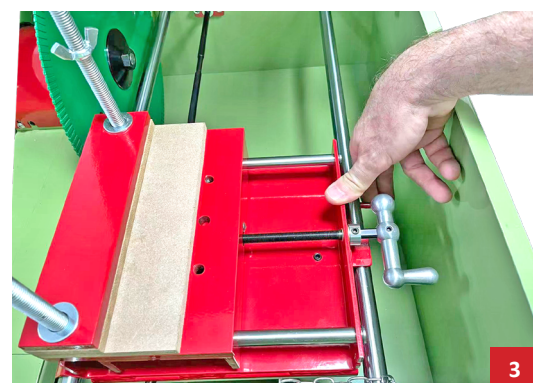
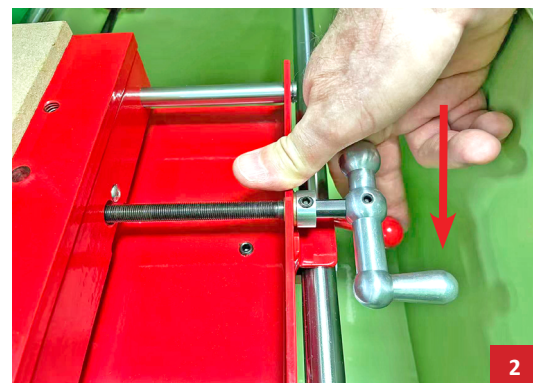
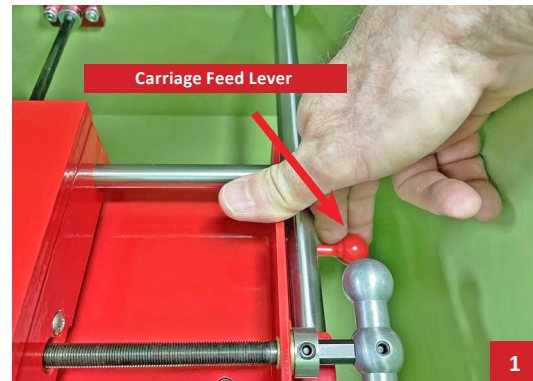

**PRO TIP:**

It is helpful to have on hand a variety of wood shims to assist in clamping rocks in any slab saw vise. Carpenter's wood shim material works very well for this as it provides "crush" to assist in conforming rocks to the saw vise and providing more contact area between the vise surfaces and the rock. Such shim material should be cut shorter than supplied lengths for use in shimming rocks for slabbing.

- 8. Set the Crossfeed for the First Cut** - Once the rock is secure, you are almost ready to begin the cut. Disengage the carriage feed lever and carefully move the carriage toward the blade, stopping when the rock is near the blade but not touching. This makes it easier to see where the blade is in relation to the workpiece. Adjust the cross-feed now to the position where you want to make the first cut. *(The photo at right looks down onto the stone to see where the first cut will start.)*

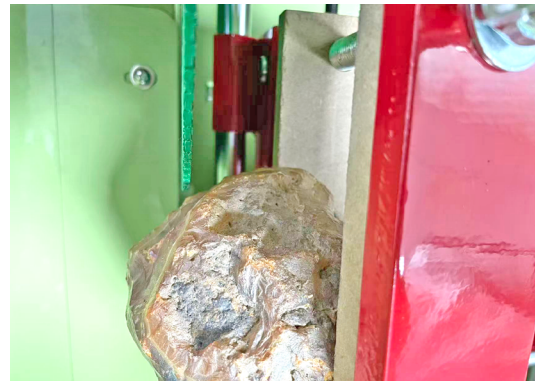
**SLAB THICKNESS TABLE****HT12/14 SAW**

1/2 inch	14 turns of crossfeed handle
3/8 inch	11 turns of crossfeed handle
1/4 inch	8 turns of crossfeed handle
3/16 inch	6.5 turns of crossfeed handle
1/8 inch	5 turns of crossfeed handle

9. Once you are satisfied with the position, you can release the carriage feed lever again and move the carriage toward the blade until the workpiece is about  $\frac{1}{4}$ " from the blade, but NOT touching! Release the carriage feed lever and then turn the blade just a little by hand to make sure it's not in contact with the workpiece.



- 10. Set the Cutoff Chain** - Next adjust the automatic cut off chain allowing sufficient travel of the carriage to cut completely through the rock. With the vise in position to begin the cut, you can hold the chain up to the carriage (#1), then add the approximate length of chain to accommodate the length of the cut (#2) and secure the chain into the notch on the right side of the carriage. (#3).

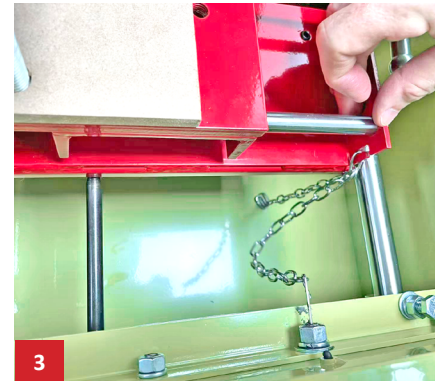
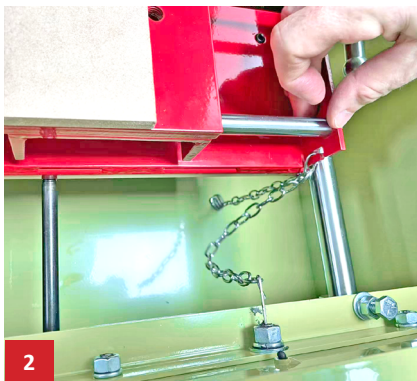

## ALTERNATIVE HOLDING VISES AND TOOLS

**The Dragon Jaw (SKU: HT1442)** - Generally its best to position the stone where there are more than two points of contact. Of course, with river or beach cobble, this is pretty impossible. In those cases, using a HP Dragon Jaw can provide more secure holding.



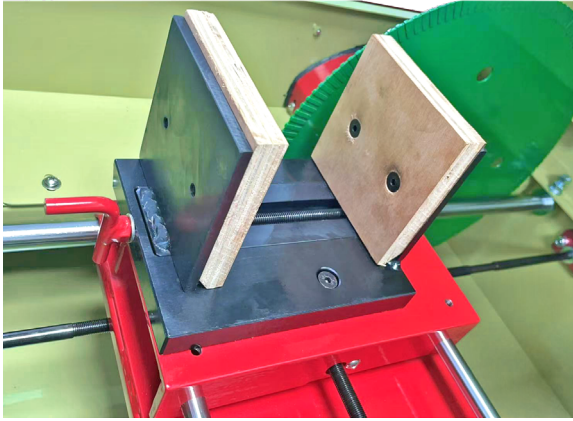

**The 4" Retrofit Vise (SKU 120004)** - This vise will mount on any HT14 Saw and is a vertical style vise. On many types of rough the vertical vise will hold the stone more securely. If you are cutting small agate nodules this vise is ideal.

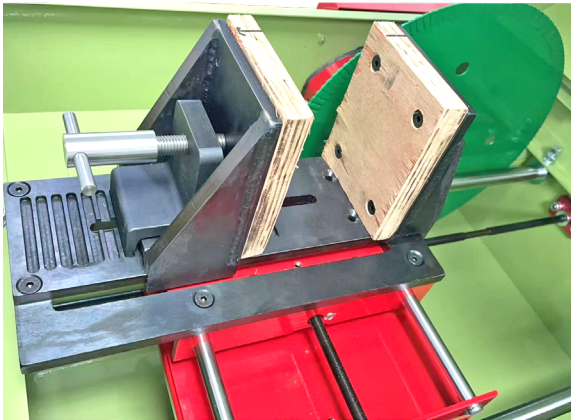

**The 5" Retrofit Vise (SKU HT1214)** - This vise will mount on any HT14 Saw and is also a vertical style vise, it has the advantage of being larger and can handle larger stones than the 4" vertical vise.

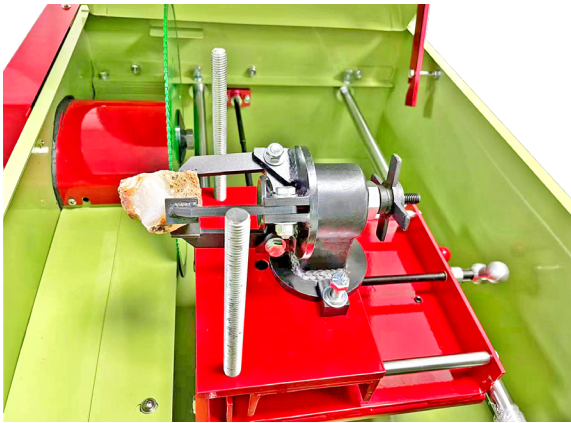

**The Small Gripper (SKU GRIP SG)** - This is a three jaw gripper that can handle some of the most unusual shapes and can be rotated or turned on an angle to accommodate many different cutting positions. The HT14 now has a lower vise plate that comes with the mounting holes for the small gripper so it's easy to just bolt it on. If you have an older saw, then you can just order (SKU HT1427) to get the newer vise lower plate.

## STARTING AND RUNNING YOUR SAW

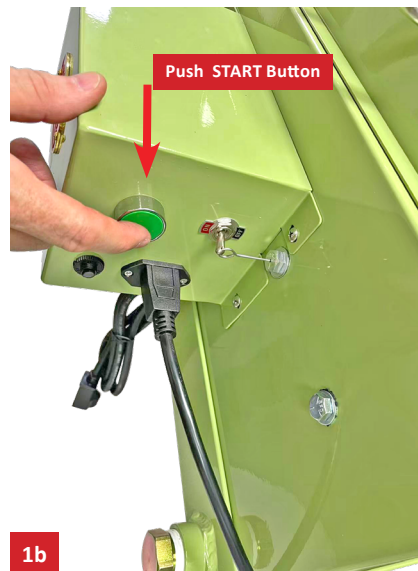

1. **Start the Saw** - Now, close the hood and ensure that the power cord is plugged into the power source. Your saw is equipped with the “Safe Start System” that reduces the risk of accidental start up of the saw. Before starting the saw, always make sure that the blade turns freely and is not touching the stone. To start the saw, set the auto shutoff toggle switch in the on position (1a) and then push and release the green start button (1b).
2. **The saw will start and run as long as the toggle switch is in the on position.** When the toggle switch is turned off manually or by the auto shut off chain the saw will stop. It won't restart until the green button is pushed again. This feature protects against accidental starting of the saw when you are loading or unloading your cutting piece.
3. **Stopping the Saw** - To stop the saw at any time, you simply turn off the toggle switch.
4. **Listen!** - Get accustomed to the sound of your saw running. When the saw is cutting well you won't hear the motor laboring and the sound of the blade in the cut will be consistent and smooth. In most cases when something goes wrong the sound of the saw will change; If the rock slips in the vise, it may change the tone of the cutting sound and if you are attentive this can help prevent damage to the blade or the stone. Some stones have internal fractures and sometimes the rock will come loose in the vise and jam the blade to a dead stop and unattended this can cause damage or destroy the motor. We recommend that you do not leave your saw unattended while cutting.
5. **The Cut is Finished** - When the cut is finished, you can either switch off the saw using the toggle switch or the trip chain when set properly will do this automatically. It's good to allow a couple minutes to allow the oil mist to settle inside the saw, but when you open the saw you should be wearing your respirator to avoid breathing any oil mist.
6. **Pull the Carriage back to the front of the saw-** After the initial cut is finished the set up process is reversed. The carriage feed lever is disengaged and the carriage withdrawn to the front of the saw. If you wish to cut a second slab, then the crossfeed is used to move the workpiece toward the blade in order to produce a slab of

the desired thickness. By noting the number of turns of the cross feed it is possible to produce successive slabs of almost identical thickness, or by using a small ruler to measure the distance from the face of the stone to the left side of the blade. Refer to the slab thickness table shown earlier in this section of the manual.

***PRO TIP: Premature Stop***

If you happen to stop the saw prematurely, and wish to restart the saw to finish the cut, then check to be sure that the blade turns easily and then close the hood, reset the toggle switch and press the green button to start the saw. Be mindful that if the blade has too much drag on it, that it may be necessary to back the carriage up about ¼" to allow the blade to spin freely. If the motor just hums and cannot turn the blade, then shut the machine off *immediately* and move the carriage back!

## CHANGING THE OIL

WATCH OUR VIDEO on CHANGING THE OIL

- 1. When does the oil need to be changed?** As you are cutting over a few weeks, you will gradually begin to see the oil getting more and more stone particles accumulate in the oil. At first it will just change the color of the oil, and then over time you will see the oil begin to get thicker. If you delay too long, the oil will become like pudding. When it gets this thick, then the job of cleaning out the saw will be much more difficult. When the oil is starting to get thicker - before it turns to pudding - is a good time to change the oil. If you change it at this point, it is also easier to filter the oil out of the dirt too.
- 2. Prepare your supplies** - It's best to get a couple of buckets and put on some work clothes and rubber gloves. Eye protection is also important in case some of the oil splashes when you are draining it.
- 3. Drain the Oil** - Position the 5 gallon bucket under the drain and open the drain valve or remove the drain plug to allow the oil to flow into the bucket. When the flow slows down, lift the back of the saw and place something under the tank so the oil flows more easily into the bucket. When most of the thinner oil has drained into the first bucket, switch to your second bucket. The thinner oil is easier to filter, so keeping the thin and thick oil separated is a good idea.
- 4. Scrape out the tank** - Use a putty knife to begin to remove any caked mud from the bottom of the tank. Sometimes it's necessary to remove the blade to clean the tank under that area if there is a lot of mud caked in that area. If you remove the blade, then be sure to clean the blade and flanges before reassembling. Don't lose the blade bushing!
- 5. Final wipe down** - Use some rags to wipe off the sides and bottom of the tank and as much of the internal mechanism as you can. In this part of the cleaning process you will see that if you don't wait too long to change the oil that this will be much easier.

6. **Close the drain** - Once you are satisfied with how clean the saw is, either replace the drain cap using teflon tape on the threads, or close the ball valve if you have one installed. If you still have something under the back of the saw, remove it and make sure the saw is still stable and level.
7. **Reinstall the blade** - If you removed your blade during the cleaning process now make sure the blade and flanges are clean and reinstall the blade according to the section on Installing the Blade shown earlier in the manual.
8. **Put fresh oil in the tank** - Add one gallon of mineral oil and then watch closely until the blade is submersed in the oil according to the section on Putting Coolant in the Tank shown earlier in the manual.
9. **Filtering the Oil** - By getting two 5 gallon pails and one lid, you can create an inexpensive filter. Use a  $\frac{3}{8}$ " -  $\frac{1}{2}$ " bit and drill holes in the bottom of one bucket (it will be your filtration bucket) spacing them about  $\frac{3}{4}$ " apart, the exact position of the holes is not important, just that there are enough of them to allow the oil to get thru. Next, cut the center out of the lid where the filtration bucket can sit on the lid with the lid on the bottom bucket. Then place a large paper grocery bag inside the filtration bucket and with it sitting on top of the lower bucket, you can now slowly pour the oil into the bag and the oil will seep through the bag into the lower bucket. Mineral oil doesn't go bad so it can be used over and over if it is filtered. When the oil has been filtered out, then the remaining mud should be disposed of in accordance with your local regulations.

## MAINTAINING YOUR MACHINE

To ensure peak performance of your machine doing some routine maintenance checks is recommended. A simple inspection of the machine can reveal small problems before they become bigger issues and thus prevent down time.

1. **Electrical cords:** Check for damaged insulation or any exposed wires and replace any damaged wiring immediately.
2. **Keep Your Blade Sharp:** Video: [SHARPENING YOUR BLADE](#)  
As you are cutting hard materials your diamond blade can become dull and you may hear the saw working harder to complete each cut. As a preventative measure, sharpening your blade each week of regular use, will help prevent blade dishing and will reduce the wear on your feed components.
3. **Loose Fasteners:** Check the machine for any loose screws or bolts, if any are found to be loose, tighten them but don't overtighten as this may damage the threads.
4. **Carriage Adjustment:** [Video: Carriage Adjustment](#)  
When you receive your saw, it's a good idea to check the carriage adjustment. We make a big effort to package our gear with the most durable packaging to protect the equipment as much as possible. Unfortunately, it's not unusual for the machine to receive some rough treatment in the shipping process. Also, as the saw is used some wear will occur and cause the carriage to become a little loose, this is easily corrected.

- A Check each of the three bearings that ride on the lower side of the carriage rails. With your finger, try to rotate the bearing and you should feel it dragging on the lower side of the carriage rail. If it turns too freely or is not touching the underside of the rail, then it's time to adjust your carriage.
  - B Get a 5/32" Allen Wrench, a Tee Handle type wrench is best, and for each bearing put your finger on the bearing turning it as you make small adjustments to tighten or loosen how the bearing contacts the rail. DO NOT just tighten the screw without turning the bearing with your finger as you are adjusting the screw as this can result in damage to the bearing bracket on the lower side of the carriage. (The screw can generate a lot of force on this bracket if its turned without checking the tightness of the bearing)
  - C The ideal adjustment is when you feel the bearing dragging against the rail as you turn it with your finger but not so tight that you cannot turn it. The two left bearings do the most work to keeping the movement of the carriage smooth, while the right hand bearing simply prevents up and down movement of the right side of the carriage, so in general you will not want the right bearing to be tight as this can cause excess drag on the carriage.
  - D When the carriage is adjusted properly, you can move it smoothly up and down the rails, but will feel no side to side or up and down movement.
5. **Arbor Alignment:** Video: [Arbor Alignment](#)
6. The ability to perfectly align your arbor with the carriage travel is very important to proper saw function and to getting good quality cuts. Additionally a poorly aligned arbor will eventually cause the blade to become dished and result in it eventually becoming unusable.
7. **Bent or Dished Blade:** With use your Diamond Blade can become bent by a rock slipping in the saw or if a small piece of the rock comes loose and damages the blade. Its a good idea to check the blade for flatness and that it's running true. If you find that you are getting tapered slabs it may be an indication that the Blade has become dished. A dished blade should be replaced.
8. **Worn out Blade:** With many hours of use eventually a Diamond Saw Blade will be worn out. This is easy to see when the blade segments are worn down until they are nearly gone. Its wise to not try to use 100% of the blade segments used up completely as the blade pressure will increase rapidly once there are no more diamonds left and this can damage the saw feed mechanism and/or the workpiece. Once a blade is worn out, replace it with a new quality Lapidary Blade. Diamond Blades that are designed for Tile or Concrete are not suitable for cutting Lapidary materials. Hard Agates and Jaspers require a different diamond matrix formula to cut properly.
9. **Greasing your Bearings:** Your slab saw has two heavy duty pillow block bearings that support the arbor shaft. These bearings come lubricated with a NLGI-2 general purpose lithium from the factory. If you are using your machine daily then you should grease your bearings once every 6 months. To access the bearings you will need to remove the red cover over the arbor bearings by loosening the 4 phillips head screws that hold the cover in place. There is silicon adhesive that prevents the oil from getting out of the left side of the saw and you will need to separate it as you open the cover, sometimes you will need to use a razor blade to get it loose. The grease fitting is on the top of both bearings, grease them and then wipe off the excess grease. Clean the cover and side of the saw carefully and remove any oil so when you seal the cover. Replace the red cover and tighten the 4 screws, then use Permatex Ultra Black to re-seal the left side of the Arbor cover.

# Warranty Coverage

## **Machines, Polishers, Diamond Blades & Core Bits and Motors**

Highland Park warrants to the original purchaser for a period of one year except as noted, from the date of purchase all products covered by this Warranty to be free of defects in materials and workmanship. This warranty is non-transferable and applies only to the original purchaser.

This Warranty shall not apply to any parts that have been subjected to misuse or improper service, that had been damaged in transit or handling, or that have been altered or repaired by unauthorized representatives. This Warranty does not cover defects caused by or resulting from misuse, abuse, neglect, or damage caused by accident or the failure to provide reasonable maintenance. This Warranty is void if the product or any of its individual components is altered or modified by the purchaser or if the product is used in a manner or with a blade not recommended by the manufacturer.

Any claim arising under this Warranty must be submitted by the original purchaser within the warranty period specified above and shall include proof of purchase. During said warranty period Highland Park shall, at its option, either replace or repair, at no charge to the original purchaser, any parts or components that are found to be defective by Highland Park. Highland Park shall not be responsible for or obligated to pay for freight or other transportation-related costs or expenses in connection with any defective products or components that are either returned to Highland Parks facility or any authorized repair station and/or any replacement products or components that are shipped from Highland Park pursuant to this Warranty.

Parts and labor needed to maintain products and the replacement of components due to normal use are the purchaser's responsibility and are not covered by this Warranty. All products or components replaced under warranty become the property of Highland Park. All replacement parts will be considered to be part of the original product and any warranty on such parts will expire coincidentally with the original Warranty. Replacement part(s) installed by anyone else will be provided without a charge for such replacement part(s), but this Warranty will not apply to labor charges in connection therewith.

IN NO EVENT SHALL ANY LIABILITY UNDER THIS WARRANTY EXCEED THE REPLACEMENT COST OF ANY DEFECTIVE PRODUCT OR COMPONENT THEREOF, AND HIGHLAND PARK SHALL NOT BE LIABLE FOR ANY INCIDENTAL OR CONSEQUENTIAL DAMAGES OR FOR ANY OTHER DAMAGE OR LOSS NOT EXPRESSLY ASSUMED AS SET FORTH HEREIN.

The foregoing constitutes an expressed warranty on the terms set forth above and is the only warranty or warranties applicable to the products it covers. All other warranties, including, without limitation, the implied warranty of merchantability and/or fitness for a particular purpose or use being denied. This limited warranty is expressly in lieu of all other warranties, whether expressed or implied.

# Troubleshooting

ISSUE	SOLUTION
Parts are missing or something was damaged during shipment.	Contact us directly at 512-348-8528.
Motor wont start	Make sure that motor is plugged into the switch box. If motor is plugged into the switch box, then check to see that the outlet or extension cord you are plugged into has power. Plugging a lamp into the power source is a good way to check this.
Motor wont start	Make sure that the hood is closed and the toggle switch is turned on. Then Push the Green Start Button.
Motor Won't Start	Check the overload, shown on page ? in the Connecting the Motor Section. If it has tripped, then push it in until it clicks and stays in.
Belt squeals when starting up	Belt tension may need to be adjusted (see Installing the Motor Section page ?)
Motor doesn't shut off when the toggle switch turns off.	Make sure that the motor is plugged into the switch box
Machine doesn't start, motor hums	Turn off the machine <i>immediately</i> and make sure the blade rotates freely. If the machine is left humming and not running, it WILL damage the motor. If your machine is new, contact your Highland Park Lapidary sales representative. Machines are covered under warranty for one year.
Feed Motor slow or not turning but main motor runs.	Unplug the motor from the switch box and then start the saw as you normally would with the hood closed, you should hear a click inside the switch box. Then you can open the hood and see if the feed screw is turning or not. If it's turning then count how many times it turns in one minute. It should be about 4 rpm. If it's not turning or is turning less than 3 rpm then the feed motor or feed motor wiring may be bad.

# EXPLODED VIEWS & PARTS LISTS

## HT-14 MAIN COMPONENTS #1

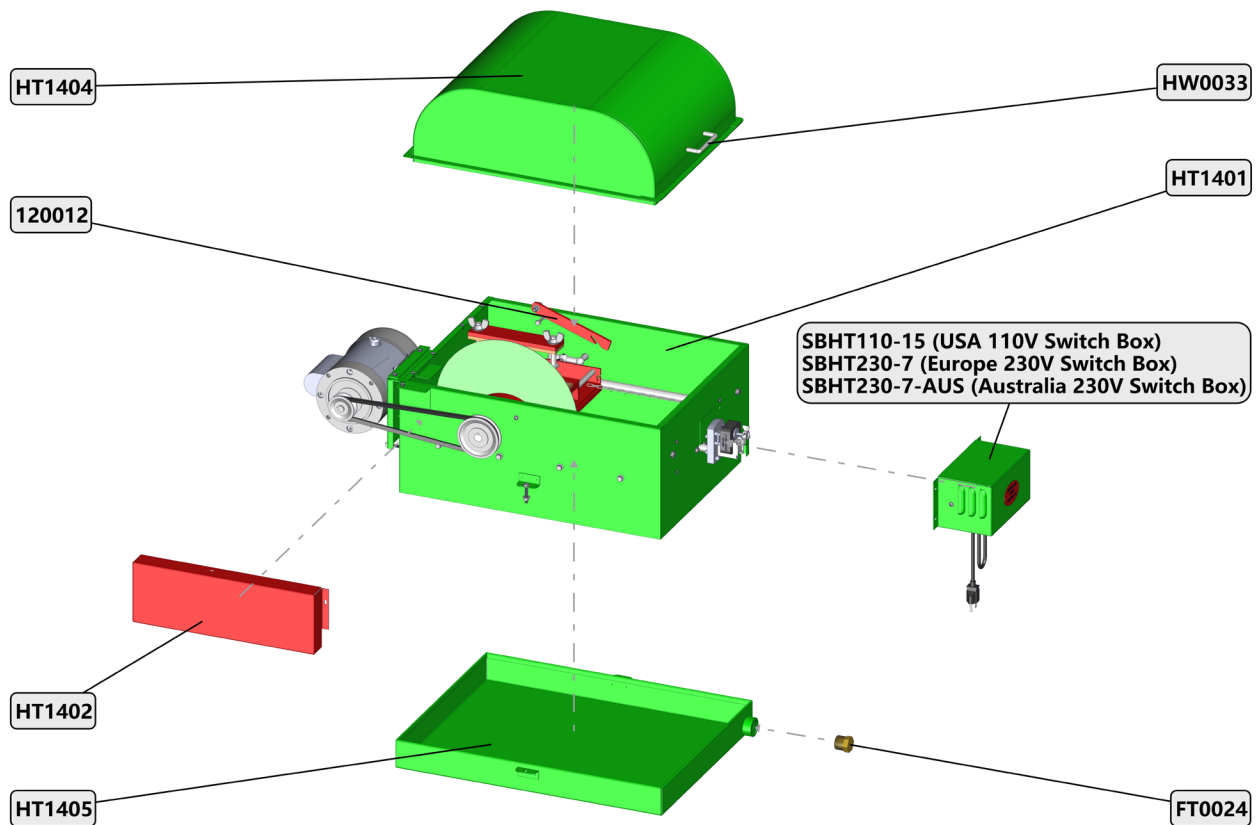

Part Number	Description	Quantity
120012	Hood Support	1
FT0024	1 inch NPT Drain Plug	1
HT1401	Saw Body Assembly	1
HT1402	Belt Guard Assembly	1
HT1404	Hood Assembly	1

HT1405	Tank Assembly	1
HW0033	Stainless Hood Handle	1
SBHT110-15	Safety Interlock Switch Box Assembly 110V with 15A overload	1

## HT-14 MAIN COMPONENTS VIEW #2

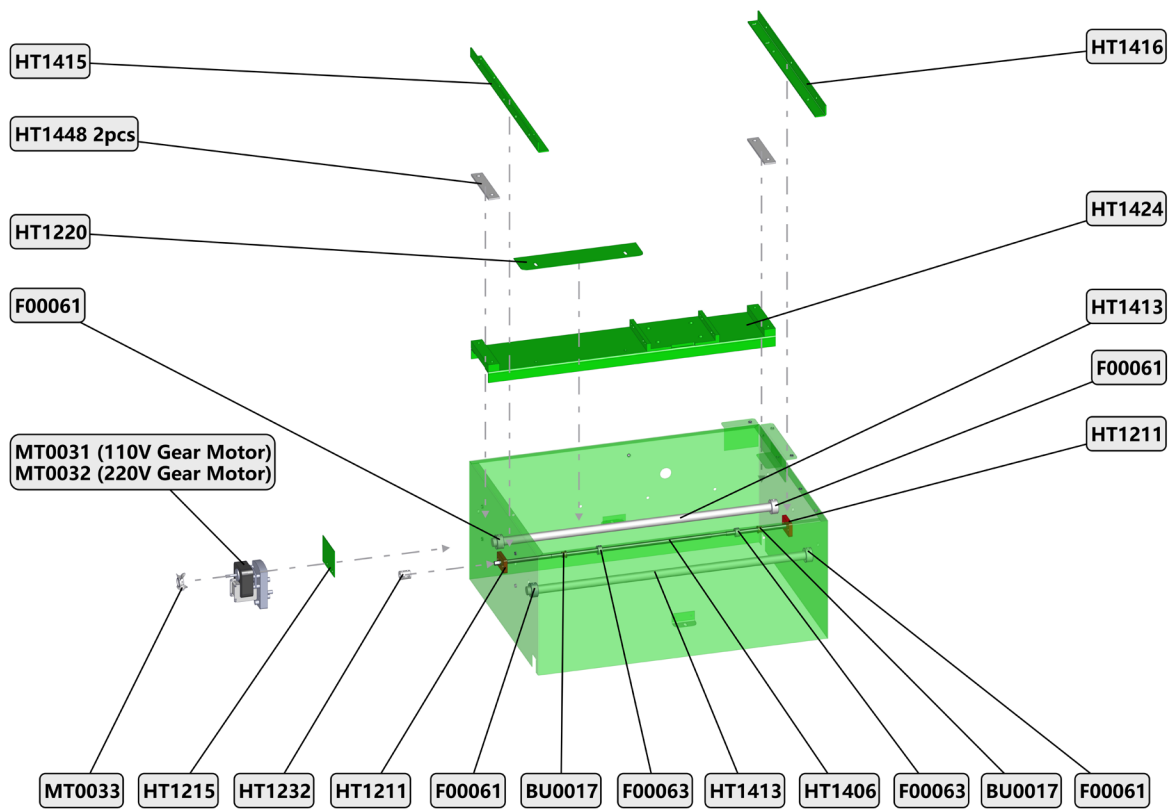

Part Number	Description	Quantity
BU0017	Front and Rear powerfeed bushing	2
F00061	3/4 Lock Collar	4
F00063	3/8 Lock Collar	2

HT1411	Front Rear Bracket	2
HT1415	Motor Rot Plate	1
HT1420	Catch Tray	1
HT1432	Motor Coupling	1
HT1437	Front Rail Bracket	1
HT1438	Rear Rail Bracket	1
HT1406	Main Feed Screw	1
HT1413	Carriage Rail	2
HT1424	Saw Arbor Base Assembly	1
MT0031	110V Gear Motor	1
MT0032	220V Gear Motor	1
MT0033	Gear Motor Replacement Fan	1

### HT-14 MAIN COMPONENTS VIEW #3

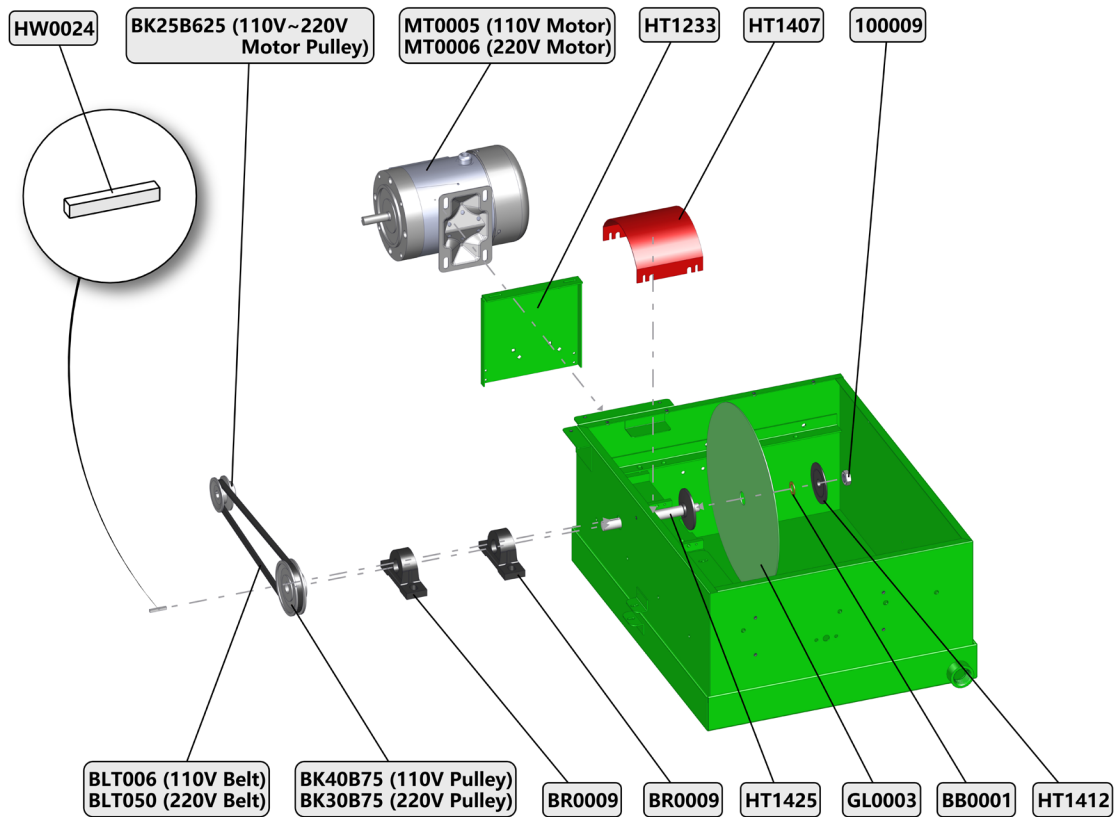

Part Number	Description	Quantity
100009	5/8-18 Arbor Nut	1
BB0001	Blade Bushing	1
BK25B625	BK25 cast iron pulley with 5/8 (.625) inch bore	1
BK30B75	BK30 cast iron pulley with 3/4 (.75) inch bore	1
BK40B75	BK40 cast iron pulley with 3/4 (.75) inch bore	1
BLT006	110V Motor A34 belt	1
BLT050	220V Motor A33 belt	1
BR0009	Pillow block arbor bearing	2
GL0003	Greenline 14 inch diamond blade	1
HT1233	Motor Mount	1
HT1407	Arbor Cover	1
HT1412	Outer Flange	1
HT1425	Arbor shaft Assembly	1
HW0024	3/16 Key Stock	1
MT0005	1725 RPM 1/2 HP 110V 60 Hz electric motor with NEMA 56 frame	1
MT0006	1440 RPM 1/2 HP 220V 50 Hz electric motor with NEMA 56 frame	1
	1440 RPM 1/2 HP 220V 50 Hz electric motor	1

## HT-14 MAIN COMPONENTS VIEW #4

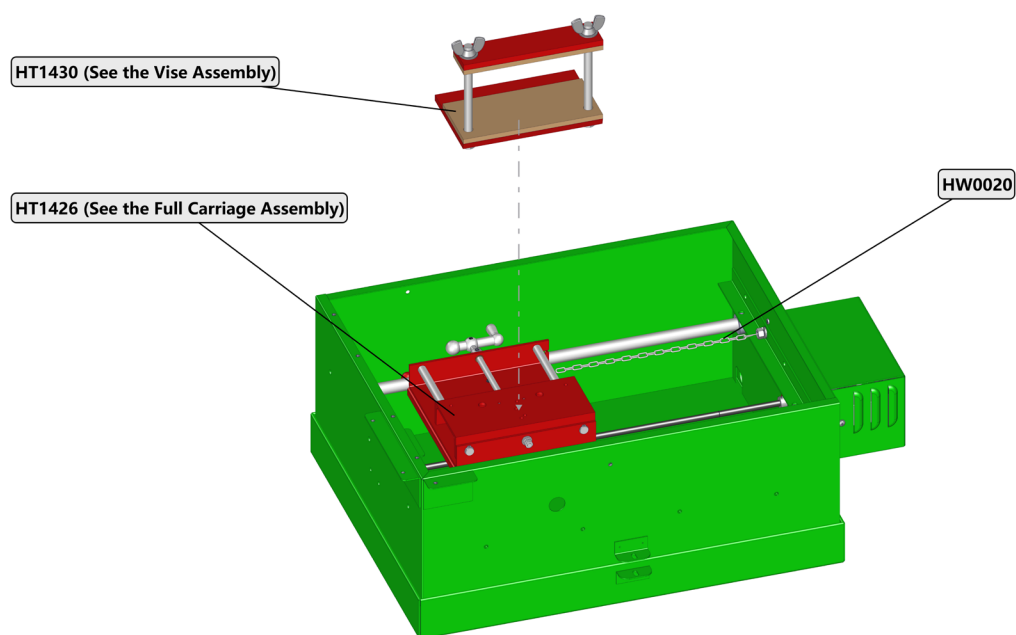

Part Number	Description	Quantity
HT1426	Full Carriage Assembly	1
HT1430	Vise Assembly	1
HW0020	Carriage Power Switch Chain	1

## HT-14 SWITCH BOX

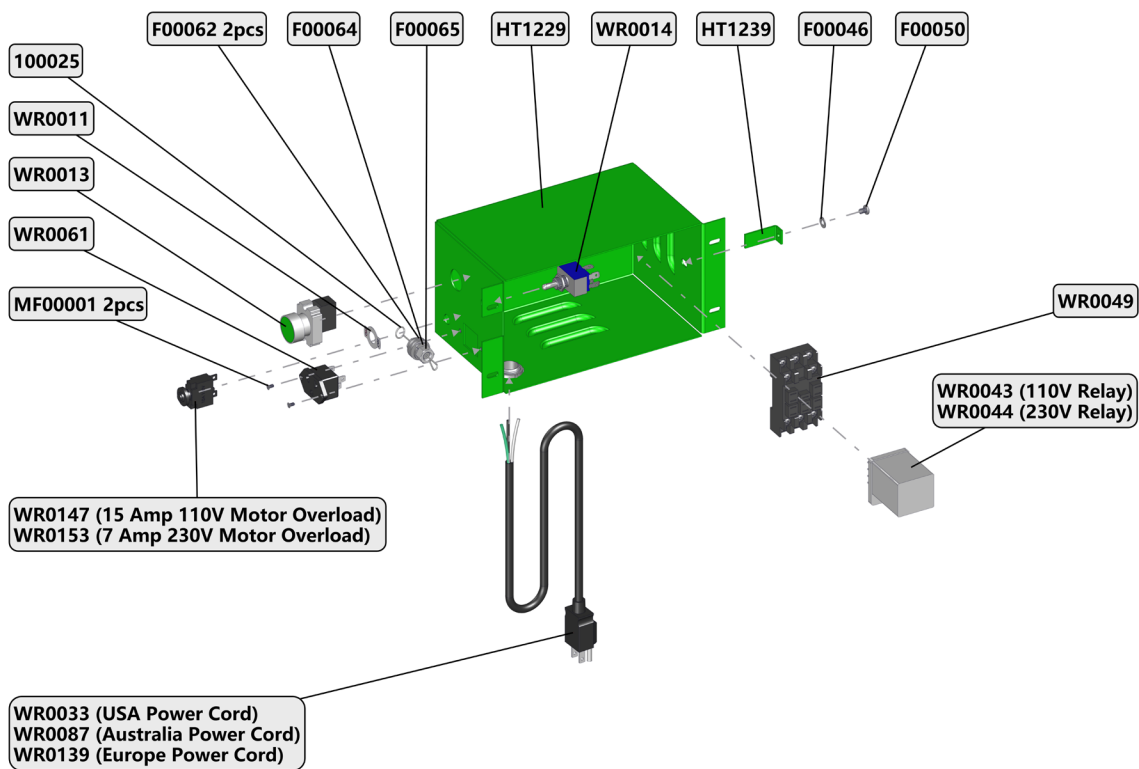

Part Number	Description	Quantity
100025	Switch Tank Through Bolt with Trip Wire	1
F00046	10-32 Flat Washer 304SS	1
F00050	10-32 x 1/4 PHP Pan Head Phillips SS304	1
F00062	3/8 Flat Washer	2

F00064	3/8 Lock Washer	1
F00065	3/8-16 Hex Nut	1
HT1229	Switch Box Sheetmetal Assy	1
HT1239	Relay Retainer Clip	1
MF00001	M3-0.5 x 6mm FHP Flat Head Phillips SS304	2
WR0011	On Off Switch Plate	1
WR0013	Push Button Switch Teleme- canique	1
WR0014	Heavy Duty Toggle Switch	1
WR0033	USA Power Cord	1
WR0043	HighTone 110v 10-12-14 relay 2nd gen	1
WR0044	HighTone 230v 10-12-14 relay 2nd gen	1
WR0049	Socket for HT 10-12-14 relays 1st gen	1
WR0061	3 Pin 110v Straight-Blade Recep- tacle	1
WR0087	Australia Power Cord	1
WR0139	Europe Power Cord	1
WR0147	15 Amp 110V Motor Overload	1
WR0153	7 Amp 230V Motor Overload	1

# HT1426 FULL CARRIAGE ASSEMBLY

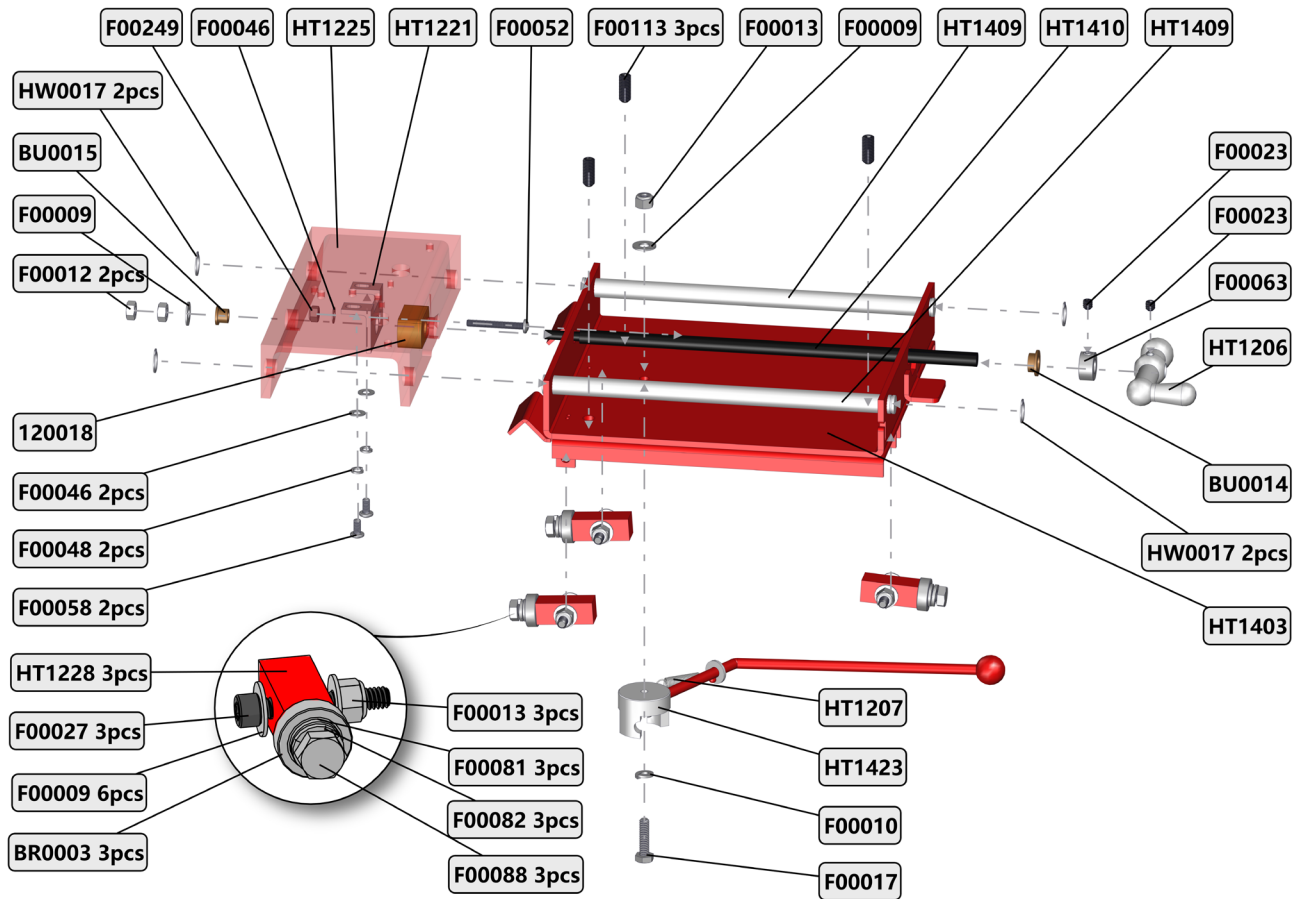

Part Number	Description	Quantity
120018	Crossfeed Nut	1
BR0003	Carriage Roller Bearing	3
BU0014	Right Carriage Crossfeed Screw Bushing	1
BU0015	Left Carriage Crossfeed Screw Bushing	1
F00009	1/4-20 Flat Washer	8
F00010	1/4-20 Lock Washer	1
F00012	1/4-20 Hex Nut	2
F00013	1/4-20 Nylon Lock Nut	4

F00017	1/4-20 x 1 HHCS Hex Bolt	1
F00023	1/4-20 x 1/4 Black Set Screw	2
F00027	1/4-20 x 1-1/2 SHCS Socket Head Cap Screw	3
F00046	10-32 Flat Washer 304SS	3
F00048	10-32 Lock Washer 304SS	2
F00052	10-32 x 1-1/2 PHP Pan Head Phillips SS304	1
F00058	10-32 x 3/8 PHP Pan Head Phillips SS304	2
F00063	3/8 Lock Collar	1
F00081	5/16-18 Flat Washer	3
F00082	5/16-18 Lock Washer	3
F00088	5/16-18 x 1 HHCS Hex Bolt	3
F00113	5/16-24 x 3/4 Black SS Set Screw	3
F00249	10-32 Nylon Lock Nut	1
HT1403	Carriage Assembly	1
HT1404	Feed nut Assembly	1
HT1406	Crossfeed Handle	1
HT1407	Feed Spring	1
HT1421	Crossfeed Bracket	1
HT1423	Crossfeed Rail	2
HT1424	Crossfeed Screw	1
HT1425	Vise Base	1
HT1428	Roller Block	3
HW0017	External Crossfeed Rail Snap Ring	4

# HT1430 VISE ASSEMBLY

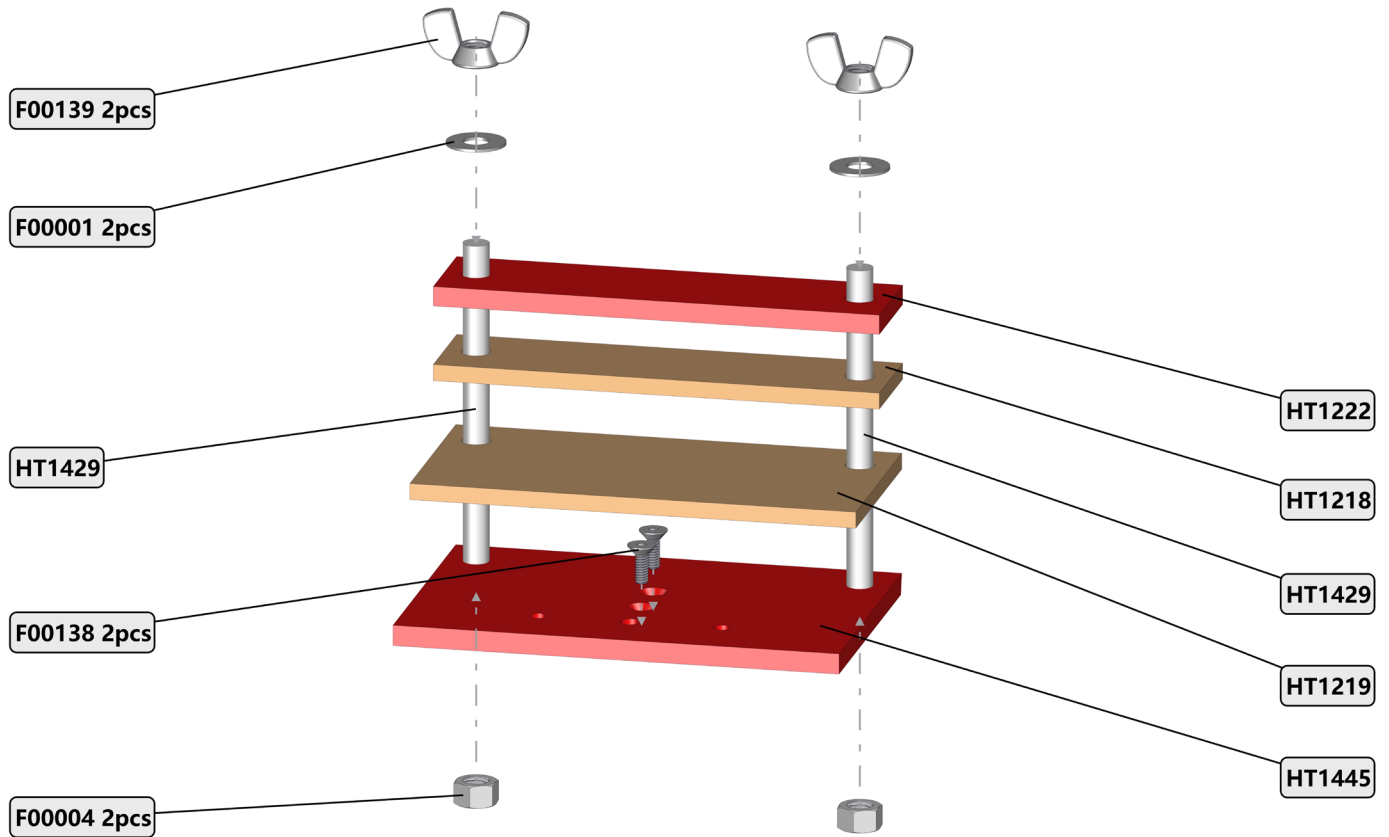

Part Number	Description	Quantity
F00001	1/2 Flat Washer	2
F00004	1/2-13 Hex Nut	2
F00138	1/4-20 x 3/4 FHSCS Flat Head Socket	2
F00139	1/2-13 Wing Nut	2
HT1418	Top Vise Wood	1
HT1419	Bot Vise Wood	1
HT1422	Vise Top	1
HT1426	Vise Rod	2
HT1427	Vise Bottom	1

## HT-14 SCREWS & FASTENERS #1

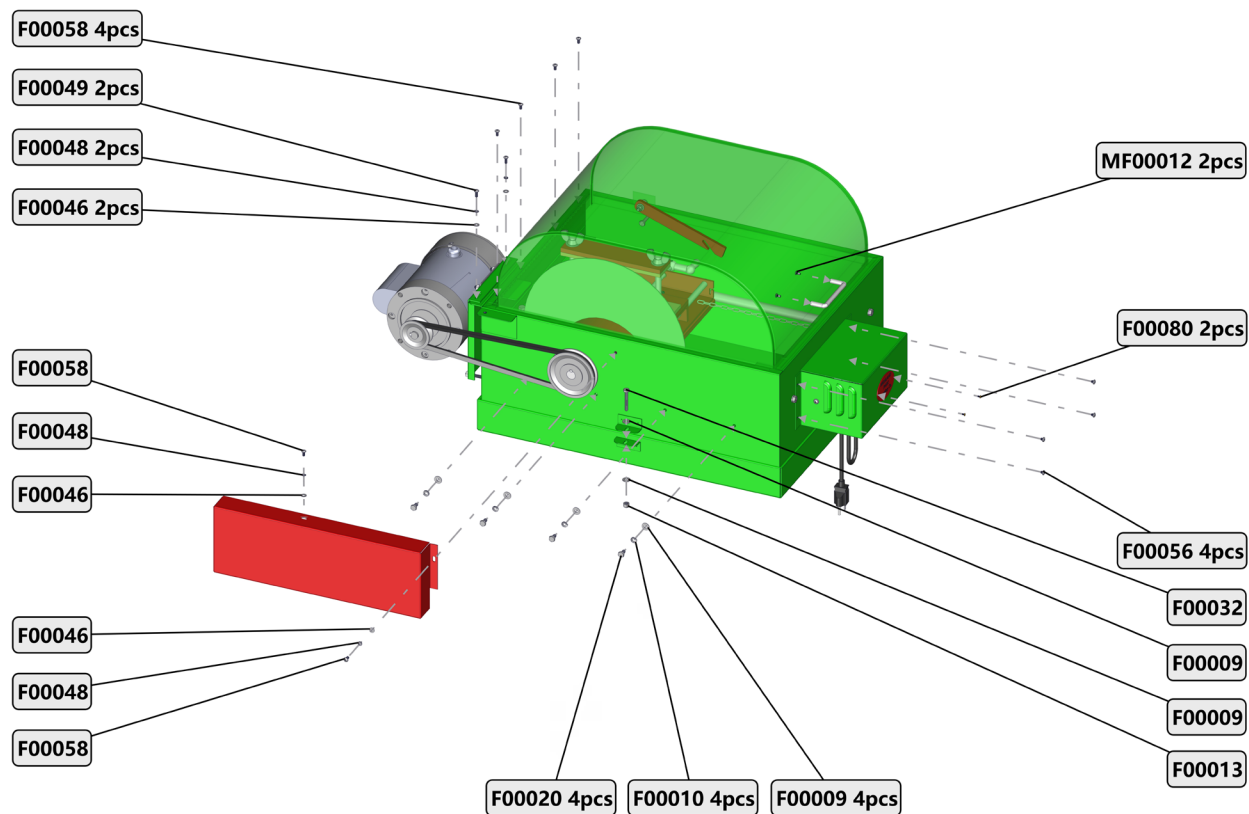

Part Number	Description	Quantity
F00009	1/4-20 Flat Washer	6
F00010	1/4-20 Lock Washer	4
F00013	1/4-20 Nylon Lock Nut	1
F00020	1/4-20 x 1/2 HHCS Hex Bolt	4
F00032	1/4-20 x 1-3/4 HHCS Hex Bolt	1
F00046	10-32 Flat Washer 304SS	4
F00048	10-32 Lock Washer 304SS	4
F00049	10-32 x 1/2 PHP Pan Head Phillips SS304	2
F00056	10-32 x 3/16 PHP Pan Head Phillips SS304	4
F00058	10-32 x 3/8 PHP Pan Head Phillips SS304	6
F00080	4-40 3/16 PHP Pan Head Phillips Brass	2
MF00012	M4-0.7 x 8mm PHP Pan Head Phillips SS304	2

## HT-14 SCREWS & FASTENERS #2

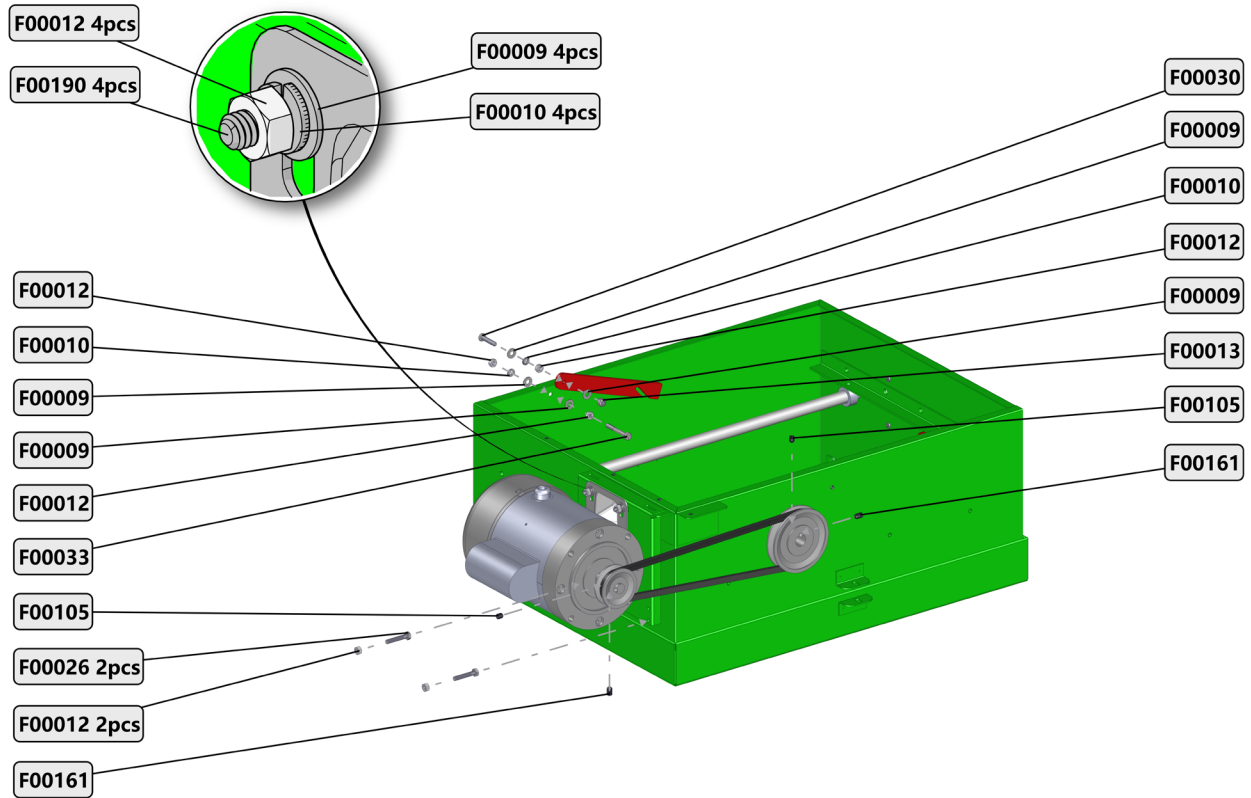

Part Number	Description	Quantity
F00009	1/4-20 Flat Washer	2
F00013	1/4-20 Nylon Lock Nut	1
F00023	1/4-20 x 1/4 Black Set Screw	4
F00032	1/4-20 x 1-3/4 HHCS Hex Bolt	1
F00046	10-32 Flat Washer 304SS	2
F00048	10-32 Lock Washer 304SS	2
F00049	10-32 x 1/2 PHP Pan Head Phillips SS304	2
F00058	10-32 x 3/8 PHP Pan Head Phillips SS304	4
F00081	5/16-18 Flat Washer	8
F00082	5/16-18 Lock Washer	8
F00084	5/16-18 Hex Nut	4
F00088	5/16-18 x 1 HHCS Hex Bolt	4
F00103	5/16-18 x 3/4 HHCS Hex Bolt	4
MF00012	M4-0.7 x 8mm PHP Pan Head Phillips SS304	2
MF00024	M4-0.7 Flat Washer SS304	2
MF00025	M4-0.7 Lock Washer SS304	2

## HT-14 SCREWS & FASTENERS #3

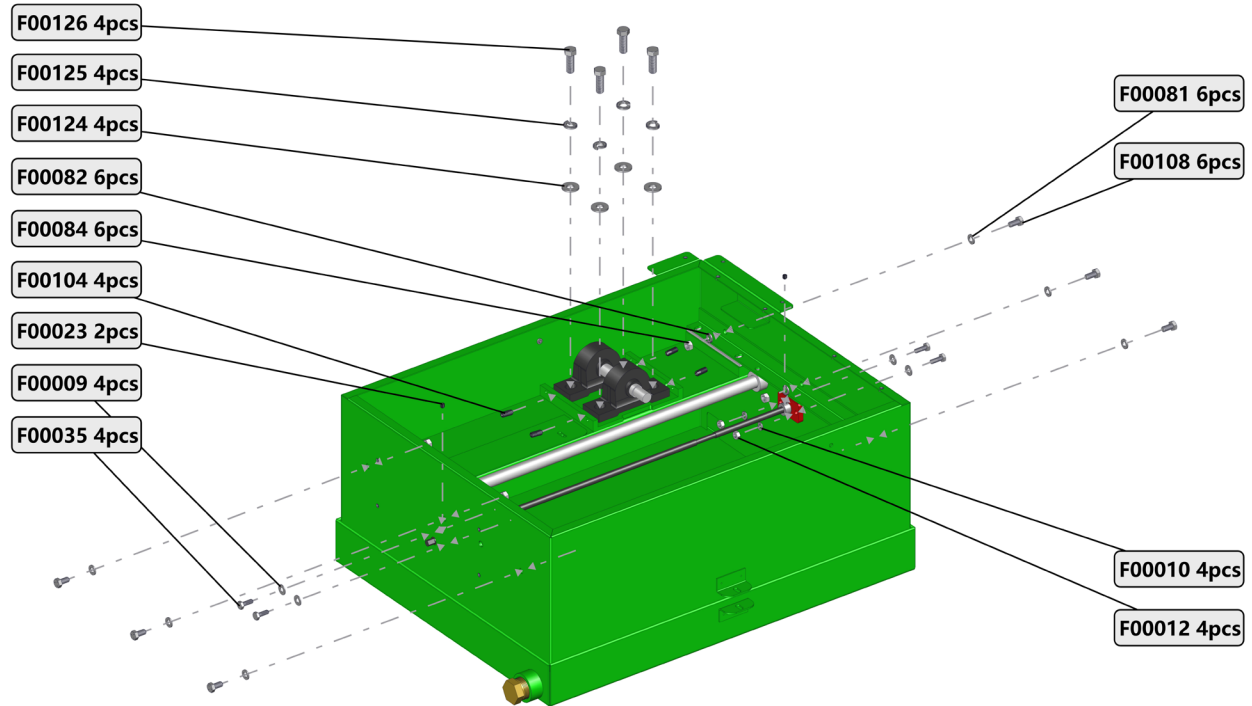

Part Number	Description	Quantity
F00009	1/4-20 Flat Washer	4
F00010	1/4-20 Lock Washer	4
F00012	1/4-20 Hex Nut	4
F00023	1/4-20 x 1/4 Black Set Screw	2
F00035	1/4-20 x 3/4 HHCS Hex Bolt	4
F00081	5/16-18 Flat Washer	6
F00082	5/16-18 Lock Washer	6
F00084	5/16-18 Hex Nut	6
F00104	5/16-18 x 3/4 Black Set Screw	4
F00108	5/16-18 x 5/8 HHCS Hex Bolt	6
F00124	7/16 Flat Washer	4
F00125	7/16 Lock Washer	4
F00126	7/16-14 x 1-1/4 HHCS Hex Bolt	4

# HT-14 SCREWS & FASTENERS #4

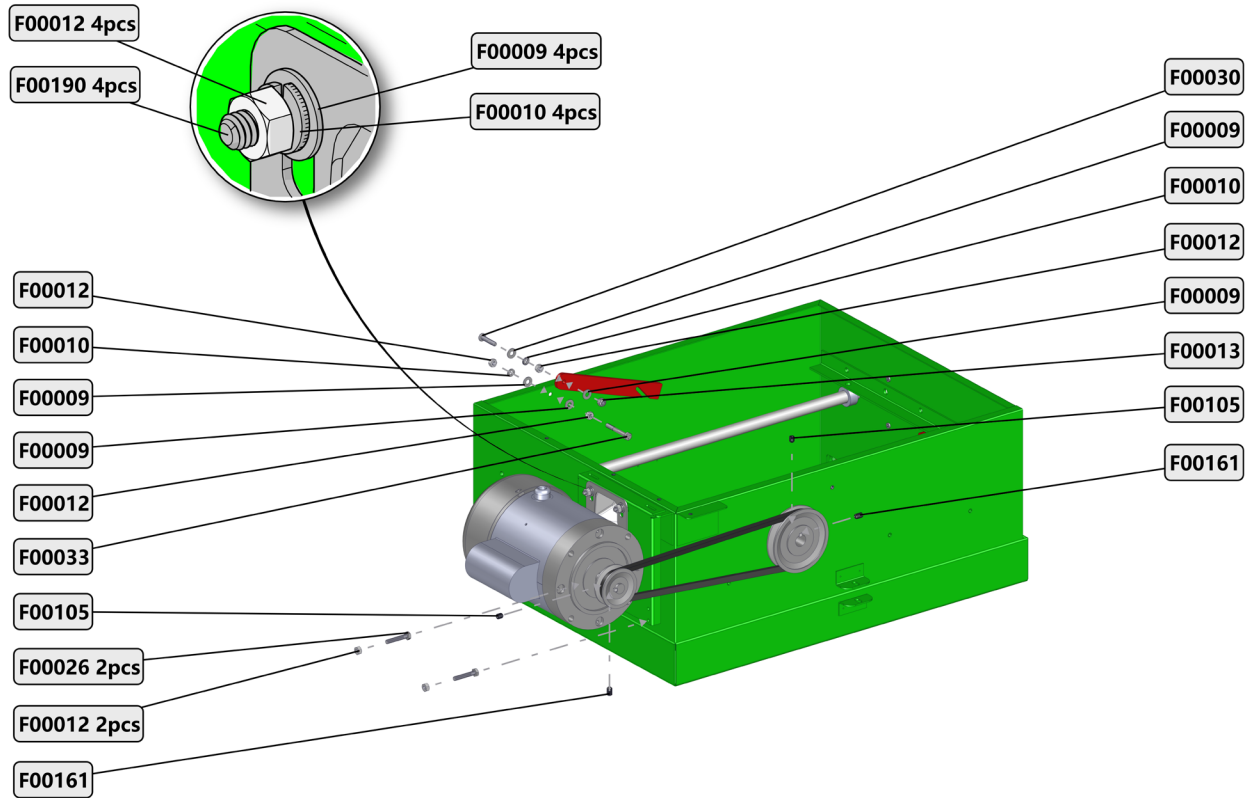

Part Number	Description	Quantity
F00009	1/4-20 Flat Washer	8
F00010	1/4-20 Lock Washer	6
F00012	1/4-20 Hex Nut	9
F00013	1/4-20 Nylon Lock Nut	1
F00026	1/4-20 x 1-1/2 HHCS Hex Head Cap Fully Threaded	2
F00030	1/4-20 x 1-1/4 304SS PHP Pan Head Phillip	1
F00033	1/4-20 x 2 HHCS Hex Bolt	1
F00105	5/16-18 x 3/8 Black Set Screw	1
F00161	5/16-18 x 1/2 inch Set Screw	3
F00190	1/4-20 x 3/4 CHCS Carriage Head Bolt	4

# Model HT-14 Slab Saw Owner's Manual & Operating Instructions







[www.hplapidary.com](http://www.hplapidary.com)

## CONTACT US

[info@hplapidary.com](mailto:info@hplapidary.com)  
512-348-8528

## FOLLOW US

-  Highland Park Lapidary Co.
-  @hplapidary
-  Highland Park Lapidary
-  @highlandparklapidary

## LIFE'S TOO SHORT TO CUT UGLY ROCKS!

HIGHLAND PARK LAPIDARY  
**LIVE EVENTS**

Mondays, Wednesdays, Thursdays  
Fridays and Saturdays  
Starts at 7:00 PM EST

