



Owner's Manual and Operating Instructions

MODEL

RT75

Rotary Tumbler



Caution: Read and Understand all Safety and Operating Instructions before using this equipment



Introduction

Let's get tumbling! Thanks for selecting the Highland Park Lapidary Model RT75 Rotary Tumbler. Our dedicated team is confident that you will be pleased with your purchase. Highland Park Lapidary takes pride in producing top quality, highly dependable products for both hobby and commercial lapidary users throughout the world.

Operated correctly, your Model RT75 Rotary Tumbler will provide you with years of quality service, and gallons of shiny stones. To help familiarize you with the features, maintenance and safe operation of the machine, we have included this owner's manual. Please take the time to acquaint yourself with the Model RT75 Rotary Tumbler by reading and understanding this manual.

If you have questions concerning your Model RT75 Rotary Tumbler, our customer service staff is waiting to help you - call 512-348-8528.

Table Of Contents

Product Safety	1
Machine Specifications	3
Setting Up Your Tumbler	3
Unpacking.....	3
Installing The Barrel Guides	4
Test Run Your Machine.....	4
Setting The Tumbler Speed	5
Process Steps: Loading The Barrel	6
Maintaining Your Tumbler	8
Rock Tumbling Checklist	10
A Quick Look At Rock Hardnes	s11
Rock Tumbling Chart	12
Troubleshooting	14
Warranty Coverage	15
Exploded Views & Parts Lists	16
Main Component	16
Barrel Assembly.....	20
Screws & Fasteners	21

Safety Precautions

If used improperly, all electrical equipment carries some risk. To eliminate danger to either yourself or the machine, please read and follow all safety, operating and maintenance instructions!

Failure to read, understand and follow these instructions could result in injury or death to you or others, result in damage and/or reduced equipment life.

NEVER OPERATE MACHINE WITH GUARDS REMOVED

Never operate the machine without the guards in place to prevent personal injury or damage to the machine.

CONNECTING AND DISCONNECTING POWER

- **DISCONNECTING** Always disconnect the machine before servicing.
- **CONNECTING** Plug the power supply into the tumbler and then into the wall. The tumbler will start to rotate once the power switch is turned on (some models) other models will start as soon as the power is plugged in.

ELECTRICAL SAFETY

- If the wiring becomes damaged or frayed, replace it immediately.
- If using an extension cord, it should be no longer than 6 feet and at least 18 gauge wire.
- Use this tool only with the proper power source 120V/220V 50/60 Hz.
- Do not allow water to come in contact with electrical components, and do not connect or disconnect the power with wet hands.
- Disconnect the power before servicing the machine.
- DO NOT place the tumbler in an enclosed space such as a box or cupboard. Overheating may cause the machine to shut down.

ROTATING OR MOVING PARTS

Keep hair and clothing away from the rotating shafts to prevent injury. Tie long hair back to keep it from getting wrapped in the mechanism. Never operate the machine with covers or guards removed.

KEEP WORK AREA CLEAN

- **Cluttered work areas invite accidents.** Keep your work area clean and organized.

- Never use the tumbler in damp or wet locations nor expose it to rain. Always keep your work area well lighted.

WORK METHOD

- **DO NOT OVERLOAD THE TUMBLER BARRELS (page 6)** Good results cannot be achieved if the barrel is improperly loaded, as stones need room to tumble.

MAINTAINING THE MACHINE

- **CHECK FOR DAMAGED OR WORN PARTS** Before using the machine, check for damaged parts or wires. ANY part that is damaged or worn should be replaced. Regularly check moving parts for proper alignment, and to make sure nothing is binding.

IMPORTANT! Although the RT75 Tumbler Motor is capable of running at speeds higher than 19 RPM, running it at maximum speed will not produce the best results and may cause bruising to the stones.

Specifications

Tumbler Model	Model RT75
Machine Weight	145 lbs.

BARREL SIZE - 75 lb. barrel assembly (12" diameter x 9.75" long, outside dimensions)

Setting Up Your Tumbler

The Highland Park Model RT75 Rotary Tumbler has been carefully packaged for protection during its trip from the factory to you. The machine has been tested to ensure that it's operating properly and that all components meet specifications. You should have the following when you unpack your unit:

If you have the Model RT75:

- Highland Park Model RT75 Drive Assembly
- 75lb. Barrel Assembly (qty 3)
- Barrel Guides (qty 2)

Tools Needed

- #2 Phillips Screwdriver

UNPACKING AND ASSEMBLING THE MACHINE

The Model RT75, 3 x 25 lb. (75Lb) Rotary Tumbler is packaged carefully to be a snug fit in the foam packing, so when lifting the machine out of the box, grip the Tumbler by the frame and lift it out of the foam packing. Lift carefully to not hurt your back or get a second person to help you if it's too heavy for you.

Your Highland Park Model RT75, Rotary Tumbler has been shipped from the factory thoroughly tested and inspected. Choose a place in your workspace for your tumbler that allows an adequate, dry working space and has a convenient power outlet. Avoid using an extension cord if possible; it's much safer to connect the machine directly to a wall power outlet.

Place the Model RT75 Rotary Tumbler on a flat, level surface.

INSTALLING THE BARREL GUIDES

The Model RT75 uses two guides that keep the barrels from rubbing against the bearings.



- Remove the screws from the frame where the guides will mount.
- Position the guide over the two screw holes making sure that the bearing is positioned where it will ride against the barrel when it's running. Carefully start the screws in the holes. Start both screws before tightening them, then tighten them but don't overtighten as this may damage the threads.

TEST RUN YOUR MACHINE

Connect the machine to the power outlet:

- Plug the power cord into the wall outlet.
- Turn on the power switch
- There will be a few second delay as the controller initializes before the machine starts turning the barrel shafts. Adjust the speed knob so shafts are turning. (See adjusting speed section before attempting to run the tumbler.)

Setting The Tumbler Speed

The Highland Park rotary tumblers are all designed to be variable speed, which gives the experienced tumbling artist the ability to accommodate different types of stone by adjusting the speed. To some degree, a faster speed can increase the smoothing of the stones, but running the tumbler too fast can create damage that is hard to clean up. Running the tumbler faster than recommended speed should be done with caution.

For the Model RT 75, we recommend starting at a speed of 19 rpm. Tumbler speed should be adjusted so that you can hear a steady, rolling grind from the rocks inside the tumbler. The speed either can be set manually by putting a piece of tape on the barrel and counting revolutions by eye using a stopwatch, or by using a tachometer.

USING THE TACHOMETER (TA001) to Measure and Set the Speed

To set the speed with the tachometer, cut a small square (approximately 1"x ½" inch) of the white sensor tape (which is included with the tachometer) and stick it to the edge of the lid. Rest the tachometer against the side edge of the tumbler.



The laser should be facing the rim with the tape. Hold the tachometer in one hand and use the other to adjust the potentiometer until the desired speed is achieved. (A video is available on the HP Lapidary Youtube channel).

PROCESS STEPS

Loading the Barrels:

1. **To open the barrel,** unscrew and remove the wingnuts on the lid, and then lift the lid and the lid gasket off the barrel.
2. **Add rock to the barrel:** Fill the barrel approximately 3/4 full of stones of assorted sizes. (approx. 25 lbs. in each barrel) A variety of sizes will help make sure the grit is distributed evenly during each phase. Be sure to use rocks of similar hardness, as mixed hardnesses can lead to poor polish. (See page 11)
3. **Add grit for coarse grind:** Add 1 Tbsp. of 60-90 silicon carbide grit for each 1 lb of rock. (approx 25 tablespoons) Keep grit off the top edge of the barrel where the lid gasket will sit to ensure a leak-free seal.
4. **Add water to the barrel** until it just reaches the top layer of the stones.
5. **Install the lid gasket on the barrel:** Ensure that the top of the barrel is clean and free of grit and stone chips, then install the inner lid.
6. **Install the outer lid:** Put the top lid on the barrel, carefully line up the barrel threaded studs until the lid slides on. Don't force it because forcing it could damage the barrel threaded studs. Replace the wing nuts on and then tighten them by hand. **(Never use a tool to tighten the barrel wing nuts)**
7. **Place the barrel onto the tumbler** between the barrel guides on the main rollers. The barrel guides will keep the barrel in the proper position as the tumbler is running.
8. **Coarse Grind** process time: Run the tumbler for 2-3 days, then open the barrels and check the stones to see that the edges are getting

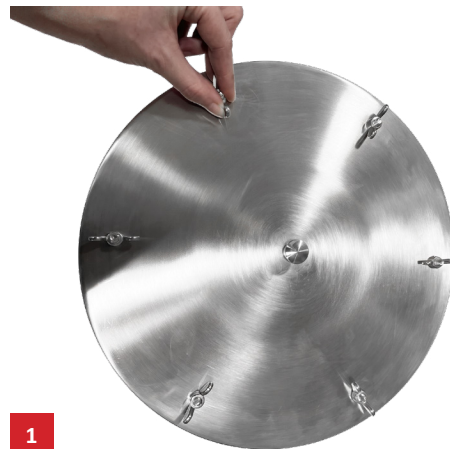

1



2



3

rounded and the stones are smooth. If the stones have not changed shape enough, add 8-12 Tbsp more grit. Reclose the barrel and run for an additional 3-4 days. Harder stones will take longer to get smooth than softer stones.

- 9. Wash the stones** to prepare for the next grit! After the stones are nicely smoothed, open the barrel and drain the contents in a strainer over a bucket. **DO NOT** dump the water down the drain, because the grit and dirt in the water will **clog the drain**. Wash the stones, the barrel and the lid with soap and water to remove *all traces* of grit. Not doing so may contaminate your next step.
- 10. Reload the barrels for Fine Grind:** Put the clean stones back in the barrel and add 1 tablespoon of fine grit for each 1lb of rock. (Typically this can be 220 graded grit or 120/220 silicon carbide, which would be ungraded equivalent.) Since a certain amount of material has been removed from the stones, it is important now to add some type of media or stone to make up the difference so the barrel can be loaded to 3/4 again. Ceramic media or plastic pellets may be used. Add water like you did in step 5 (just until stones are covered) then reclose the barrel. Run it for another 5-7 days, checking it again after 2-3 days. After completing this step, you should see the stones becoming much more smooth. When the stones are consistently smooth all over, then repeat the wash process (step 10) for cleaning the stones and the barrel and lid.
- 11. Reload the barrels for Pre-Polish:** Put the stones back in the barrel, adding media as required to get the barrel to 3/4 full. For this step we recommend using about 30% more grit so if you have 25 lbs of stone you will put in 25 tablespoons and then another 30% (8 more tablespoons). Typically this is 500 to 600 grit silicon carbide. Reclose the barrel and run for another 5-7 days, checking it again after 2-3 days. After completing this step, the stone will start to look much more shiny. When you can see that the surfaces of the stones are consistently shiny, then repeat the wash process (step 10) for cleaning the stones, barrel and lid.
- 12. Reload the barrel for Final Polish:** Put the stones back in the barrel with the appropriate amount of media to have the barrel 3/4 full. For this step we recommend using about 30% more grit so if you have 25 lbs of stone you will put in 25 tablespoons and then another 30% (8 more tablespoons) (Depending on the stone, this is typically 2500 to 5000 grit aluminum oxide). Run the tumbler for another 5-7 days, checking it again after 2-3 days. After completing this step, the stone will look perfectly polished. When you can see that the surfaces of the stones are consistently shiny and bright, it's time to take them out of the tumbler! Repeat the process (step 10) for cleaning the stones, barrel and lid. You now have your first batch of finished tumbled stones!

Maintaining Your Tumbler

Your Highland Park Model RT75 3 x25lb. (75Lb) Rotary Tumbler has been designed to require minimal maintenance to keep polishing your treasures for years. To help it keep running smoothly, *the following regular maintenance is important:*

Greasing the Shaft Bearings:

Greasing the shaft bearing once each 3-4 months of running, use NLG1 lithium grease. Put only 1 pump of grease in each bearing and wipe any excess grease away and keep it off the rubber part of the Main Rollers as it can cause the barrel to slip.

Cleaning the Barrel:

The barrel liner can be cleaned with soap and warm water both inside and outside. Do not use any solvents or try cleaning the barrel in the dishwasher, as these can damage the barrel.

Motor, Controller and Fan:

The motor and control system on your Highland Park Model RT65lb Rotary Tumbler uses brushless DC motor technology. The motor and controller do not require any service, but you should routinely check to make sure that the fan is always functioning when the machine is running. If the fan is not operational when the machine is on, then the fan should be replaced.

General Cleaning:

With use, your Highland Park Model RT65 Rotary Tumbler may get some dust and oil residue on it. Keeping your machine clean is a good way to keep it looking great and avoid issues like grit contamination. Unplug the tumbler before wiping it down. You can use a mild cleaning solution like Formula 409 or Simple Green, but don't spray the cleaner directly on the machine. Instead, spray the solution on your cleaning rag, and then use the rag to wipe the surfaces of the machine.

Checking for Worn Parts:

Your Model RT65 is designed for long life and trouble-free service. However, with any machine there are components that will wear over time depending on the level of use. For your machine the following parts are considered wear parts:

Barrel Lid Gasket

This is the most common wear part on rotary tumblers, the life of this part will be affected by the hardness and how sharp the stone that is being tumbled is. When this part is worn out, the barrel will begin to leak some. We recommend keeping an extra gasket on hand.

Guide Rail Rubber Sleeves

The barrel rides on these rubber sleeves, which help allow the barrel to rotate without slipping. Over time, the sleeves may start to get grooves in them. If the barrel starts slipping, then it's time to replace them.

Barrel Liner

The barrel liner will last a long time. However, it is considered a wear part because the rocks and grit rotating within the barrel liner will eventually wear down the wall thickness of the barrel liner with the abrasive tumbling action. When the barrel liner develops a hole, then it must be replaced.

Barrel guide bearings

The barrel guide bearings ride against the barrel, protecting the barrel and keeping it from rubbing the bearings. If the barrel guide bearings rubber coating wears off or if the bearings become difficult to rotate then they should be replaced.

Bearings

There are four bearings that the main rails run on. Following the recommendation for periodic lubrication will allow these bearings to last a long time. There is a grease fitting on every bearing where they are able to be greased

- Over time if the bearings become loose or if they don't rotate smoothly and/or the barrel rotation becomes erratic, then it is time to replace them.



Rock Tumbling Checklist

COARSE GRIND

- Add rock to barrel - 3/4 full of small stones of assorted sizes.
- Add 6 Tbsp. 60/90 silicon carbide grit to the barrel, keeping edge clean.
- Add water to barrel until it just covers the top of stones.
- Install both lids and tighten brass nut by hand.
- Place barrel into the tumbler and align the barrel guide
- Run for 3-4 days total, or until stones are smooth.
- Check for progress after 2-3 days. If rocks are not changing, add 3 Tbsp. more grit
- Wash the stones, barrel and lid COMPLETELY before next grit.

FINE GRIND

- Place stones in barrel. Fill with media until 3/4 full.
- Add 1 Tbsp 120/220 grit to the barrel for each pound of stone
- Add water to top of stones and media until they are just covered.
- Install both lids and tighten brass nut by hand.
- Place barrel onto the tumbler between the barrel guides
- Check for progress after 2-3 days. If rocks are not changing, add 2-3 Tbsp. more grit.
- Run for 5-7 days.
- Wash the stones, barrel and lid COMPLETELY before next grit.

PREPOLISH

- Reload barrel, adding media to get 3/4 full.
- Add 33 Tbsp of 500-600 grit silicon carbide.
- Add water to top of stones and media until they are just covered.
- Install both lids and tighten the wing nuts by hand.
- Place barrel onto the tumbler between the barrel guides
- Run for another 5-7 days.
- Wash the stones, barrel and lid COMPLETELY before the next grit.

FINAL POLISH

- Reload barrel, adding media to get 3/4 full
- Add 33 Tbsp. of polish (6 lb.) or 16 Tbsp. (12 lb.) (2500-5000 grit aluminum oxide)
- Add water to top of stones and media until they are just covered.
- Install both lids and tighten the wing nuts by hand.
- Place barrel onto the tumbler between the barrel guides
- Run for another 5-7 days.
- Clean the stones, barrel and lid. You now have your first batch of tumbled stones!

A Quick Look At Rock Hardness

ROCK TUMBLING GUIDE to HARDNESS

The Mohs Hardness Scale is the standard way geologists and lapidary enthusiasts refer to a rock's relative resistance to scratching. Tumbling rocks that have similar hardnesses is the only way to get a good polish, as harder stones will wear away softer stones, and the softer stones will leave a hazy surface on the harder stones.. Beginners should consider starting with stones Mohs 7 or higher, as they are more likely to get good results. Rocks with a Mohs of less than 4 generally will not give you good results when tumbling.

The following is a short list of the types of stones that have each hardness. This is only a partial list. To determine the hardness of your rocks, you may want to purchase a hardness scratch test kit, available online.

- MOHS 10: Diamond
- MOHS 9: Corundum
- MOHS 8: Topaz, Emerald, Beryl
- MOHS 7: Agates, jaspers, petrified wood, quartz, tiger's eye, mookaite
- MOHS 6.5: Quartzite, flint, chert, jadeite, olivine, unakite, amazonite, basalt, aventurine,
- MOHS 6: Moonstone, feldspar, prehnite, diopside, rhodonite, nephrite, labradorite,
- MOHS 5-6: Dalmatian stone, opal, hematite, sodalite, obsidian, goldstone, lapis lazuli, turquoise, apatite
- MOHS 3.5-5: Magnesite, fluorite, dolomite, malachite, rhodochrosite, serpentine

Rock Tumbling Chart

	Step 1	Step 2	Step 3	Step 4
COMPOUND	60/90 Silicon Carbide	120/220 Silicon Carbide	Pre-Polish Aluminum Oxide	Polish Aluminum Oxide
75 lb. Barrel	75 Tbsp.	75 Tbsp.	99 Tbsp.	99 Tbsp.

Common Tumbling Problems

I FOLLOWED ALL THE STEPS, AND MY ROCKS ARE STILL HAZY!

Possible solutions:

- Barrel cleaning between stages may not have been sufficient, contaminating the grit from one stage to the next. This will leave micro-scratches on the surface of the stones, which no amount of polishing will remove without going back to the previous grit. Be sure you clean rocks, barrel and lid until they are completely clean and free of grit.
- Tumbling rocks of varying stone hardnesses can make it more difficult to get a good polish. The softer stones wear against the harder ones, breaking down and making the polish less effective. Be sure the rocks you use have similar hardness values.
- A tumbler barrel that is less than 3/4 full will not polish as well as one that is loaded properly. As the rocks tumble down, be sure to use media such as ceramic or walnut shells to create a full load.

MY EDGES (OR CENTERS, OR INDENTS) WON'T POLISH!

Possible solutions:

- **ONLY EDGES POLISHED** - Bring load up to 3/4 full so that the tumbling action of the rocks, media and grit can

work properly

- **ONLY CENTERS POLISHED** - Slurry is likely too thin. Return to the fine grind stage and repeat the tumbling process.
- **INDENTS WON'T POLISH** - Add more small stones or ceramic media to the tumbling batch so that the grit will have a chance to work in the smaller areas. Return to the prepolish stage.

MY STONES ARE BREAKING IN THE MACHINE

Possible solutions:

- Fractures that already exist in a stone will be stressed by the tumbling movement of the barrel. This may cause stones to break. In order to eliminate as much breakage as possible, inspect your tumbling stones carefully for fractures and breaks. Stones also may fracture if the tumbling speed is set too high. Be sure to set your tumbler to the proper tumbling speed, and make sure to decrease it with each polishing step.

MY STONES ARE BREAKING IN THE MACHINE

Possible solutions:

- Scratching can occur when a batch is tumbled with too many preforms or slabs in the mix. Tumbling experts recommend no more than 20% preforms or slabs in each barrel, with the rest being stones or media.
- Other possible causes for scratching include leftover grit or debris in the polishing phase. Even one small piece can cause scratches, which is why it's so crucial to keep your barrels spotless.

Troubleshooting

PROBLEM	CAUSE	SOLUTION
Barrel does not turn or slips	Rubber Drive Sleeve is slipping	Replace Drive Shaft Rubber Sleeve
Tumbler Drive shaft is not turning	No Power to the unit	Check the wall outlet to be sure its working
	Drive Belt is broken	Open the unit and inspect the drive belt, if damaged or broken then replace
	Controller failure	Replace Controller
Barrel is rubbing against the bearings or barrel guide bearings are not rolling smoothly.	Barrel guide bearings may have failed	Check the guide bearings to insure that the rubber coating is in good shape and that the bearing rotates smoothly. If damaged, replace the guide bearings
Barrel Leaking	Barrel lid is not installed correctly	Periodically open the barrel to vent excess gas.
	Excess Gas is building up in the barrel during operation (certain stones may do this more than others)	The barrel nut should never be tightened with any tools, only by hand. If the wing nuts are tightened with a tool this can distort the barrel lid making it so it cannot make a good seal. If the outer lid is damaged or warped, then it must be replaced.
	Barrel Wing Nuts are improperly tightened	Open the barrel and inspect the inner lid gasket for holes or tears, replace it if damaged.

Warranty Coverage

Machines, Polishers, Diamond Blades & Core Bits and Motors

Highland Park warrants to the original purchaser for a period of one year except as noted, from the date of purchase all products covered by this Warranty to be free of defects in materials and workmanship. This warranty is non-transferable and applies only to the original purchaser.

This Warranty shall not apply to any parts that have been subjected to misuse or improper service, that had been damaged in transit or handling, or that have been altered or repaired by unauthorized representatives. This Warranty does not cover defects caused by or resulting from misuse, abuse, neglect, or damage caused by accident or the failure to provide reasonable maintenance. This Warranty is void if the product or any of its individual components is altered or modified by the purchaser or if the product is used in a manner or with a blade not recommended by the manufacturer.

Any claim arising under this Warranty must be submitted by the original purchaser within the warranty period specified above and shall include proof of purchase. During said warranty period Highland Park shall, at its option, either replace or repair, at no charge to the original purchaser, any parts or components that are found to be defective by Highland Park. Highland Park shall not be responsible for or obligated to pay for freight or other transportation-related costs or expenses in connection with any defective products or components that are either returned to Highland Parks facility or any authorized repair station and/or any replacement products or components that are shipped from Highland Park pursuant to this Warranty.

Parts and labor needed to maintain products and the replacement of components due to normal use are the purchaser's responsibility and are not covered by this Warranty. All products or components replaced under warranty become the property of Highland Park. All replacement parts will be considered to be part of the original product and any warranty on such parts will expire coincidentally with the original Warranty. Replacement part(s) installed by anyone else will be provided without a charge for such replacement part(s), but this Warranty will not apply to labor charges in connection therewith.

IN NO EVENT SHALL ANY LIABILITY UNDER THIS WARRANTY EXCEED THE REPLACEMENT COST OF ANY DEFECTIVE PRODUCT OR COMPONENT THEREOF, AND HIGHLAND PARK SHALL NOT BE LIABLE FOR ANY INCIDENTAL OR CONSEQUENTIAL DAMAGES OR FOR ANY OTHER DAMAGE OR LOSS NOT EXPRESSLY ASSUMED AS SET FORTH HEREIN.

The foregoing constitutes an expressed warranty on the terms set forth above and is the only warranty or warranties applicable to the products it covers. All other warranties, including, without limitation, the implied warranty of merchantability and/or fitness for a particular purpose or use being denied. This limited warranty is expressly in lieu of all other warranties, whether expressed or implied.

Exploded Views & Parts Lists

RT75 MAIN PARTS #1

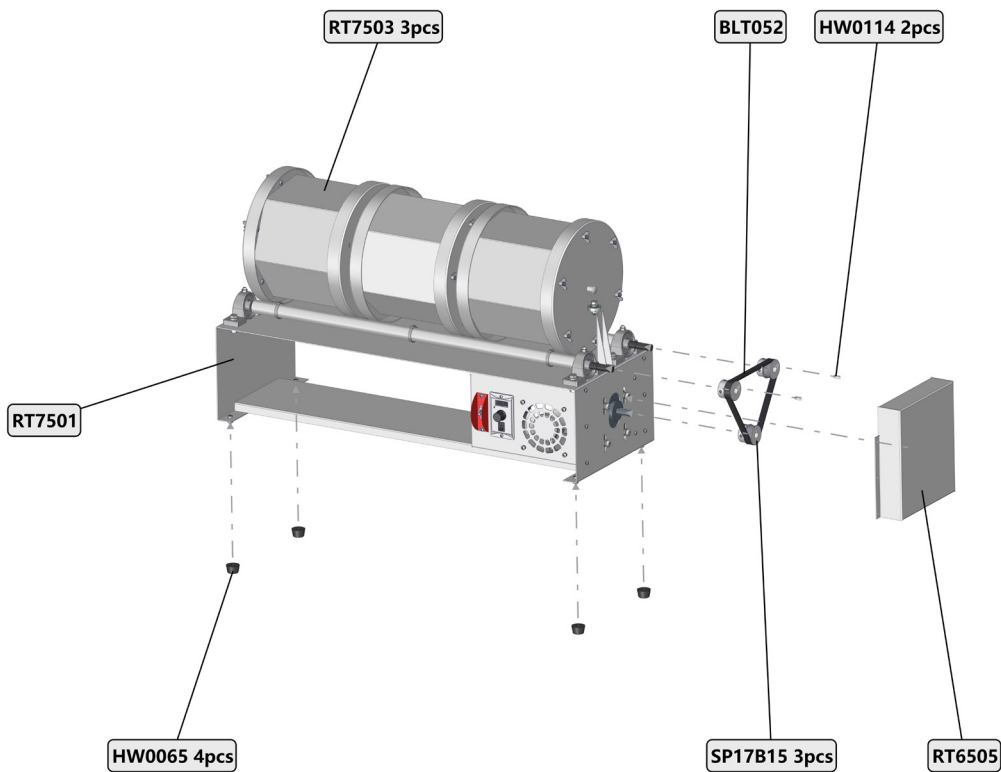

Part Number	Description	Quantity
BLT052	Serpentine Belt	1
HW0065	Rubber Foot	4
HW0114	5mm Key Stock	2
RT6505	Belt Guard	1
RT7501	Frame Assembly	1
RT7503	Barrel Assembly	1
SP17B15	Motor Pulley	3

RT75 MAIN PARTS #2

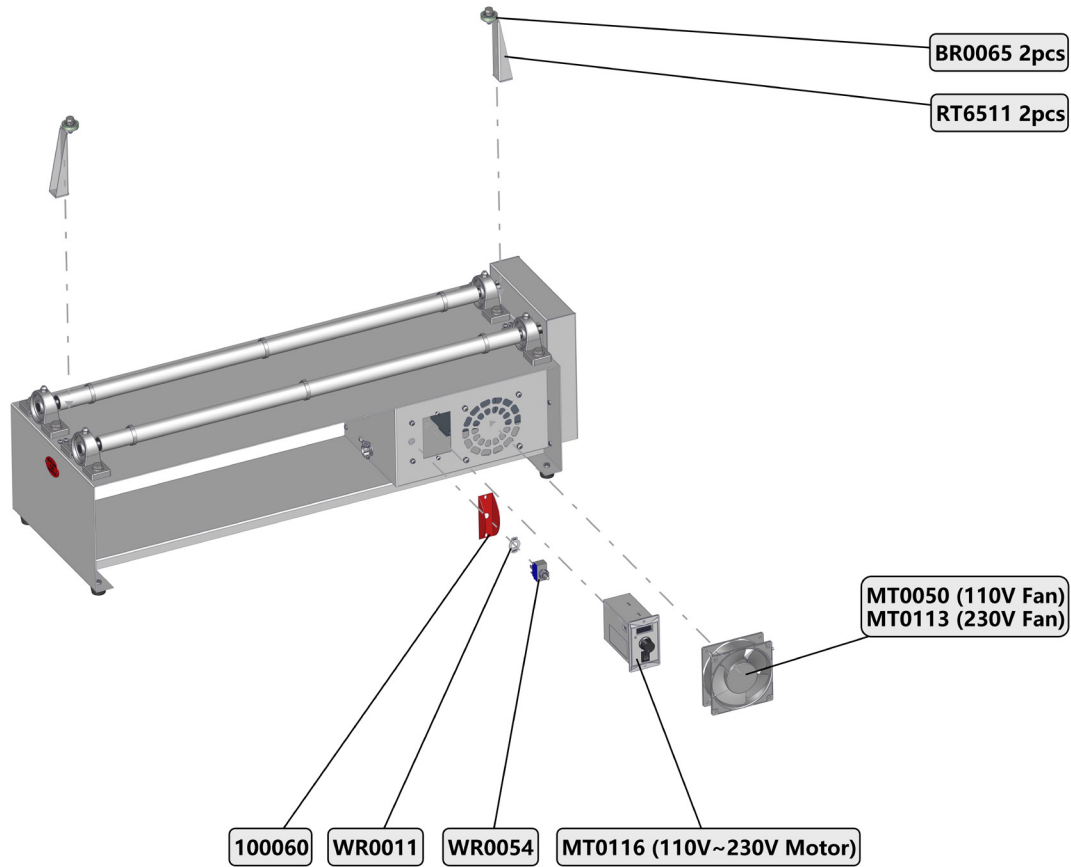

Part Number	Description	Quantity
100060	Toggle Switch Guard	1
BR0065	Bearing	2
MT0050	110V Fan	1
MT0113	230V Fan	1
MT0116	110V~230V Controller	1
RT6511	Barrel Guide Assembly	2
WR0011	On Off Switch Plate	1
WR0054	Heavy Duty Toggle Switch	1

RT75 MAIN PARTS #3

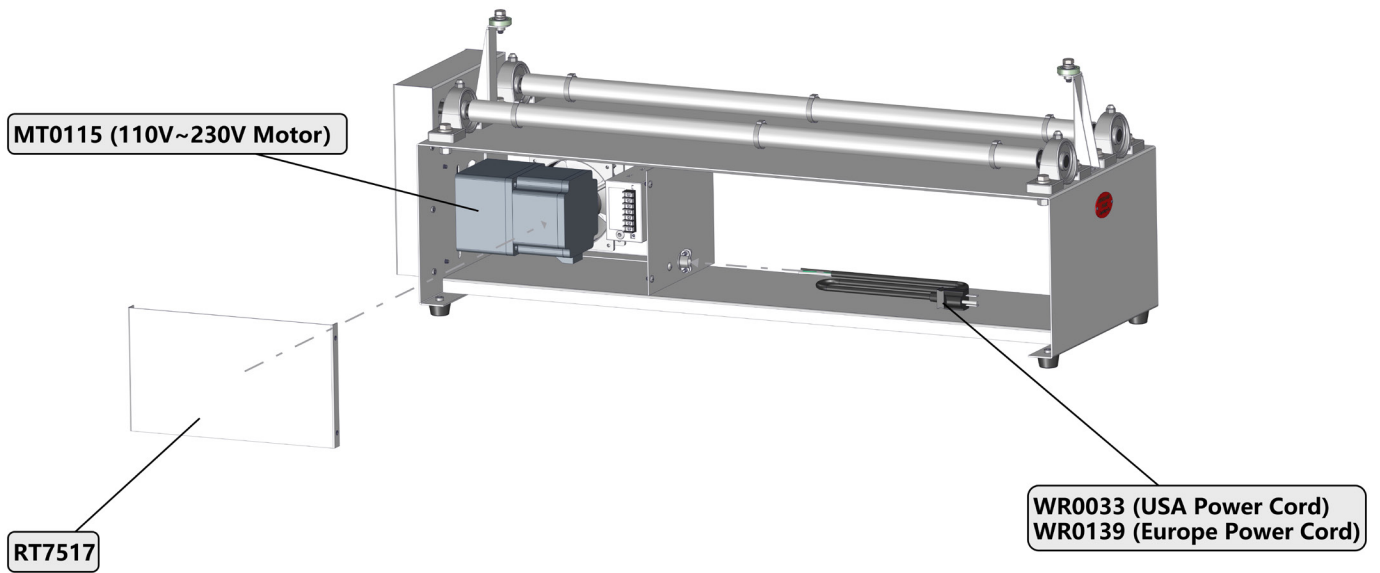

Part Number	Description	Quantity
MT0115	110V~230V Motor	1
RT7517	Motor Mount Cover Assembly	1

RT75 MAIN PARTS #4

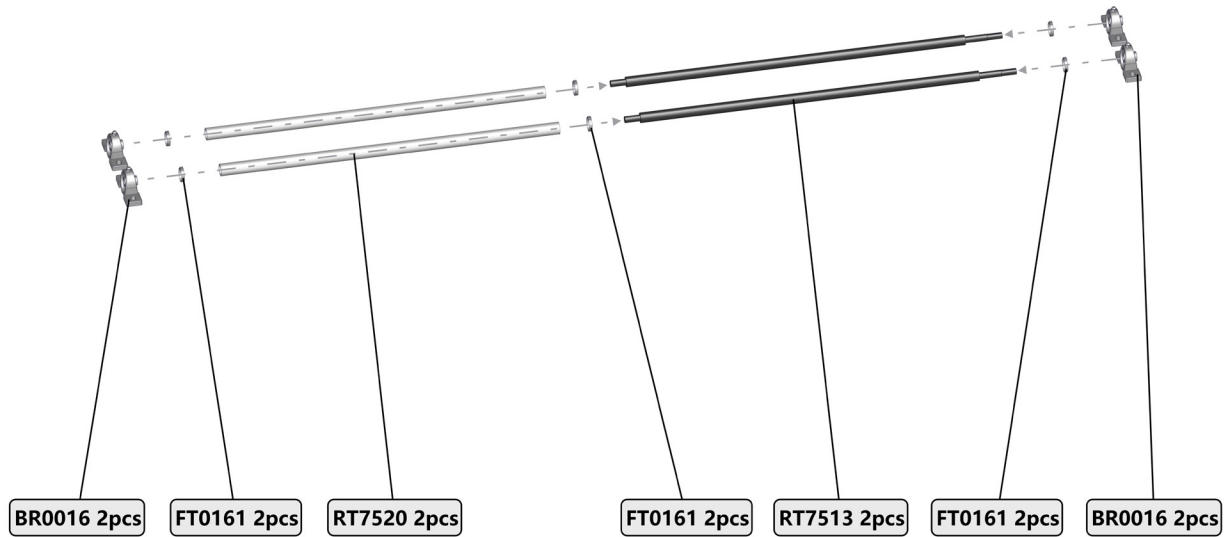

Part Number	Description	Quantity
BR0016	Drive Shaft Bearing	4
FT0161	Single Pinch Clamp	6
RT7513	Main Shaft	2
RT7520	Shaft Rubber Sleeve	2

RT75 BARREL ASSEMBLY

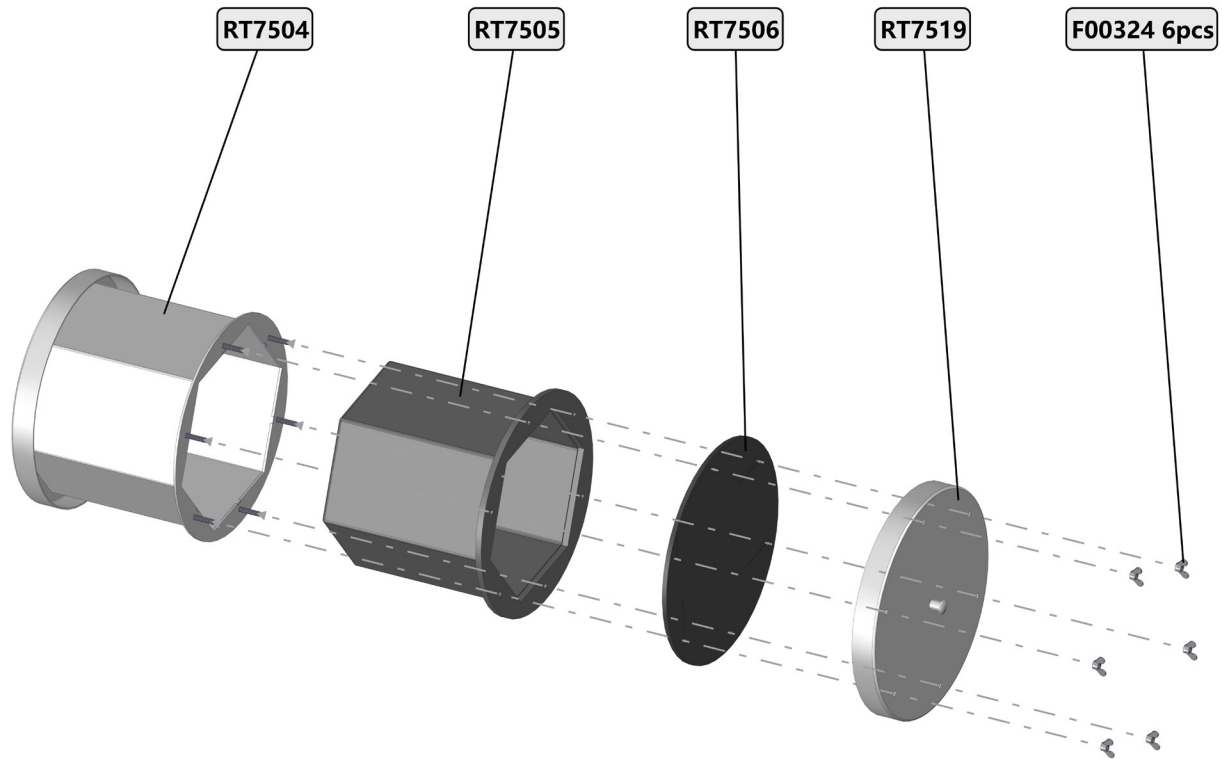

Part Number	Description	Quantity
F00324	1/4-20 Wing Nut	6
RT7504	Barrel Body Assembly	1
RT7505	Barrel Liner	1
RT7506	Barrel Inner Lid	1
RT7519	Barrel Lid Welding Assembly	1

RT75 SCREWS & FASTENERS #1

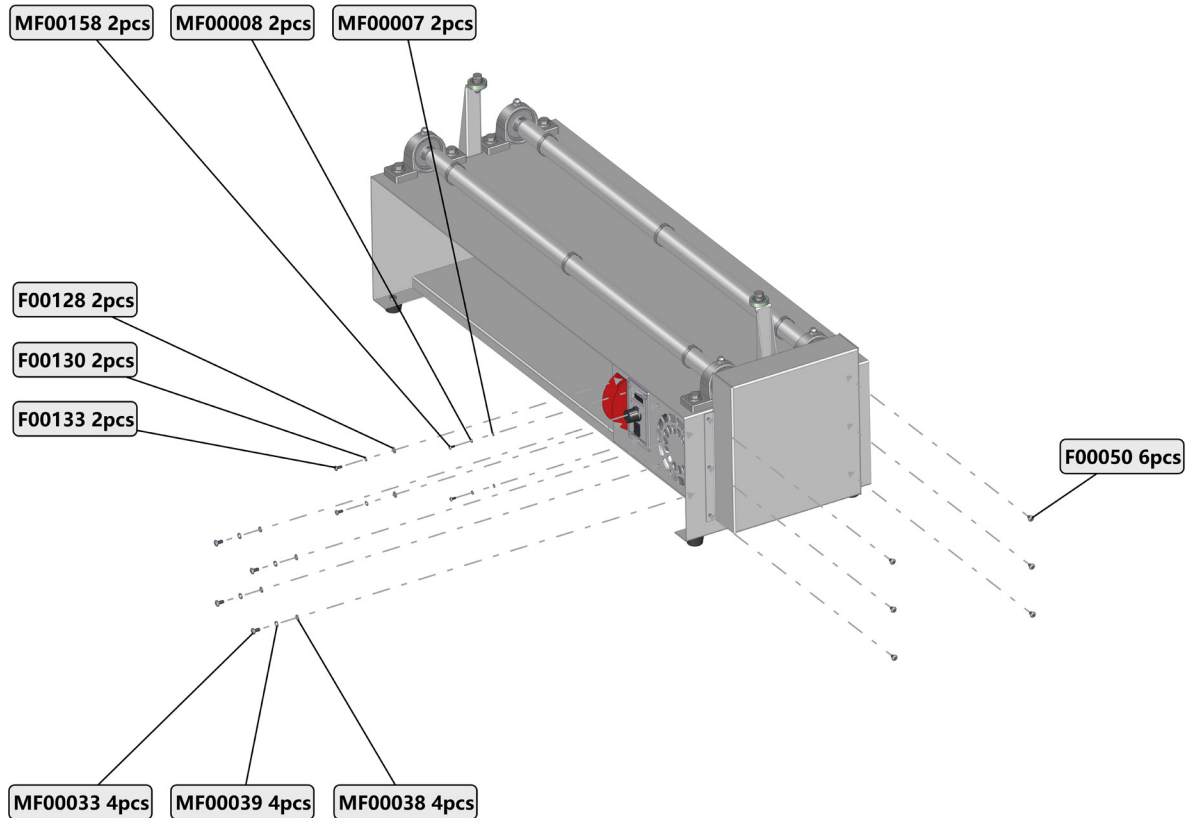

Part Number	Description	Quantity
F00050	10-32 x 1/4 PHP Pan Head Phillips SS304	6
F00128	8-32 Flat Washer	2
F00130	8-32 Lock Washer	2
F00133	8-32 x 3/8 PHP Pan Head Phillips SS304	2
MF00007	M3-0.5 Flat Washer SS304	2
MF00008	M3-0.5 Lock Washer SS304	2
MF00033	M5-0.8 x 10mm Pan Head Phillips SS304	4
MF00038	M5-0.8 Flat Washer SS304	4
MF00039	M5-0.8 Lock Washer SS304	4
MF00158	M3-0.5 x 8mm Phillips Head Cap Screw SS304	2

RT75 SCREWS & FASTENERS #2

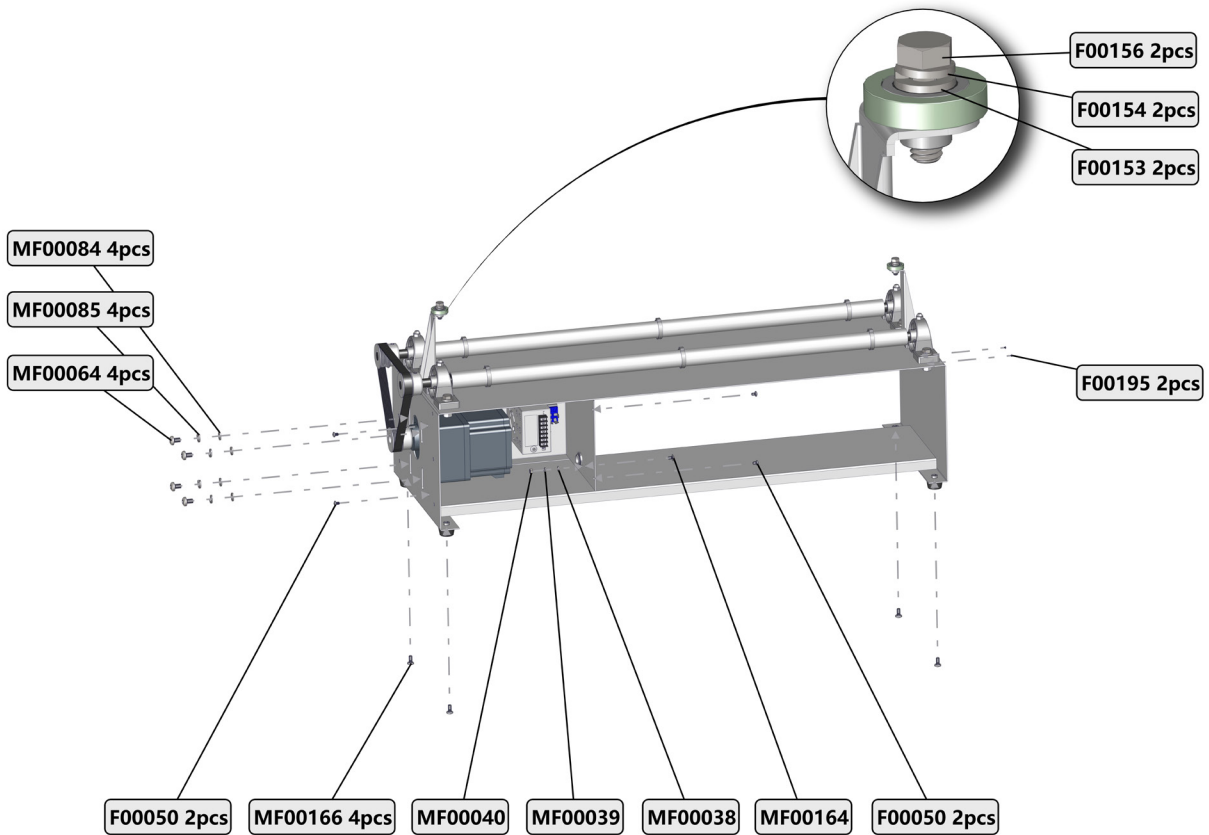

Part Number	Description	Quantity
F00050	10-32 x 1/4 PHP Pan Head Phillips SS304	4
F00153	5/16-18 Flat Washer 304SS	2
F00154	5/16-18 Lock Washer 304SS	2
F00156	5/16-18 x 1 inch Hex Bolt 304SS	2
F00195	2-56 x 3/16" PHCS Brass Pan Head Phillips Screw	2
MF00038	M5-0.8 Flat Washer SS304	1
MF00039	M5-0.8 Lock Washer SS304	1
MF00040	M5-0.8 Hex Nut	1
MF00064	M8-1.25 x 12mm Pan Head Socket	4
MF00084	M8 Flat Washer 304SS	4
MF00085	M8 Lock Washer 304SS	4
MF00164	M5-0.8 x 8mm Pan Wide Head Phillips SS304	1
MF00166	M6-1.0 x 12mm PHP Pan Head Phillips SS304	4

RT75 SCREWS & FASTENERS #2

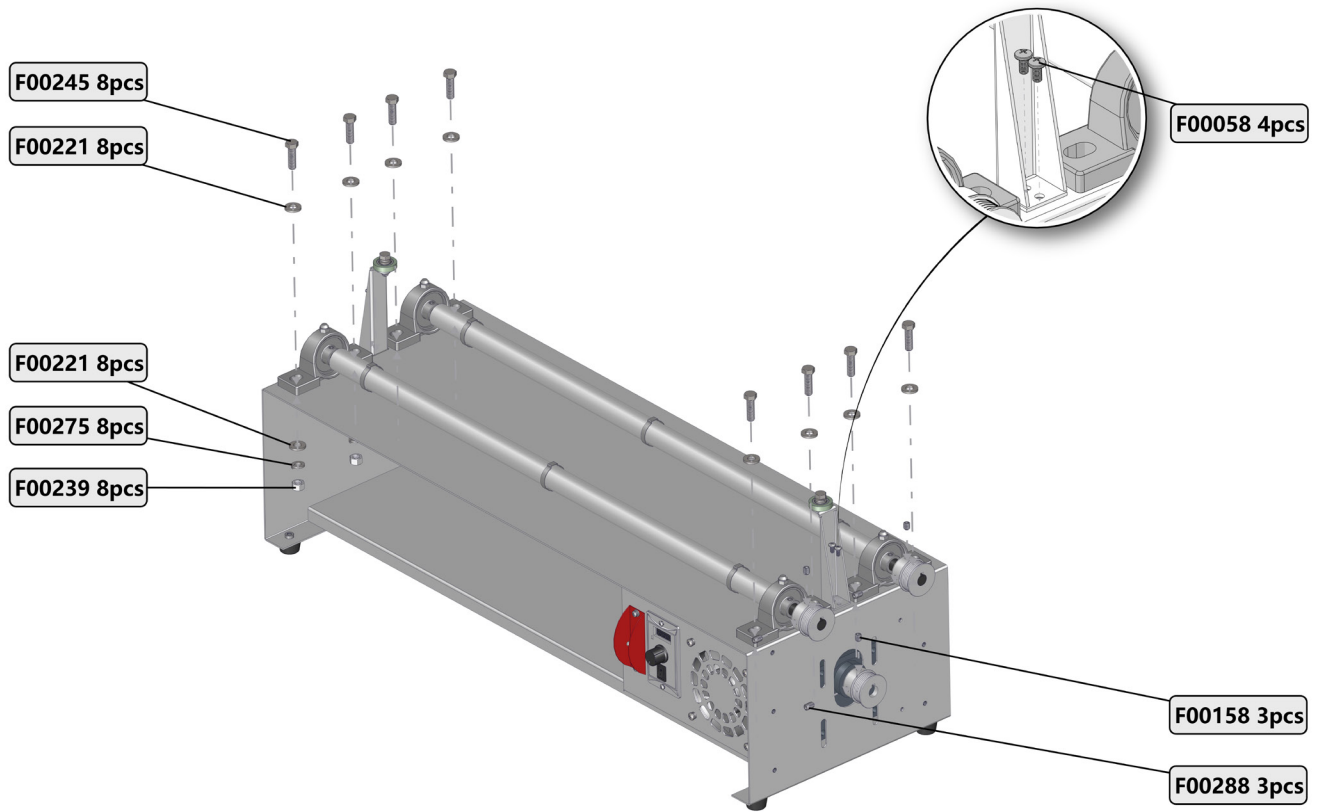

Part Number	Description	Quantity
F00058	10-32 x 3/8" PHP Pan Head Phillips SS304	4
F00158	5/16-18 x 3/8 inch SS Set Screw SS304	3
F00221	3/8 Flat Washer 304SS	16
F00239	3/8-16 Hex Nut 304SS	8
F00245	3/8-16 X 1-1/4 HHCS Hex Bolt 304ss Fully Threaded	8
F00275	3/8 Lock Washer 304SS	8
F00288	5/16-18 x 1/2 Set Screw 304SS	3

Model RT75: Rotary Tumbler Owner's Manual & Operating Instructions







www.hplapidary.com

CONTACT US

info@hplapidary.com
512-348-8528

FOLLOW US

-  Highland Park Lapidary Co.
-  @hplapidary
-  Highland Park Lapidary
-  @highlandparklapidary

LIFE'S TOO SHORT TO CUT UGLY ROCKS!

HIGHLAND PARK LAPIDARY
LIVE EVENTS

Mondays, Wednesdays, Thursdays
Fridays and Saturdays
Starts at 7:00 PM EST

